

PRIME

PRODUCT GUIDE 2023/2024

moll moll moll moll moll

moll moll moll moll moll

moll moll moll moll moll

moll moll moll moll moll

moll moll moll moll moll

moll moll moll moll moll

moll moll moll moll moll

INDEX

moll

EDITORIAL	P. 04
CLAIM	P. 08
BRAND PROMISE	P. 10
PATENTED FUNCTIONS	P. 16

PRIME

DESKS	P. 26
DESK CHAIRS	P. 74
STORAGE FURNITURE	P. 90
ACCESSORIES	P. 102
LIGHT	P. 112

IMPRINT	P. 122
---------	--------





EDITORIAL

Dear Readers,
after decades of pioneering in durability, functionality, and design, our products are made to optimally adapt to the needs of their users.

Thought out down to the smallest detail, they fulfil the requirements for maximum concentration, maximum ergonomics and adaptability.

Made in Germany - On the Swabian Alb in Gruibingen, we produce in accordance with the highest quality standards, and mainly use regional raw materials.

Martin Moll

Martin Moll is responsible for the development and design of the moll products with passion and flair.

FROM THE SWABIAN ALB

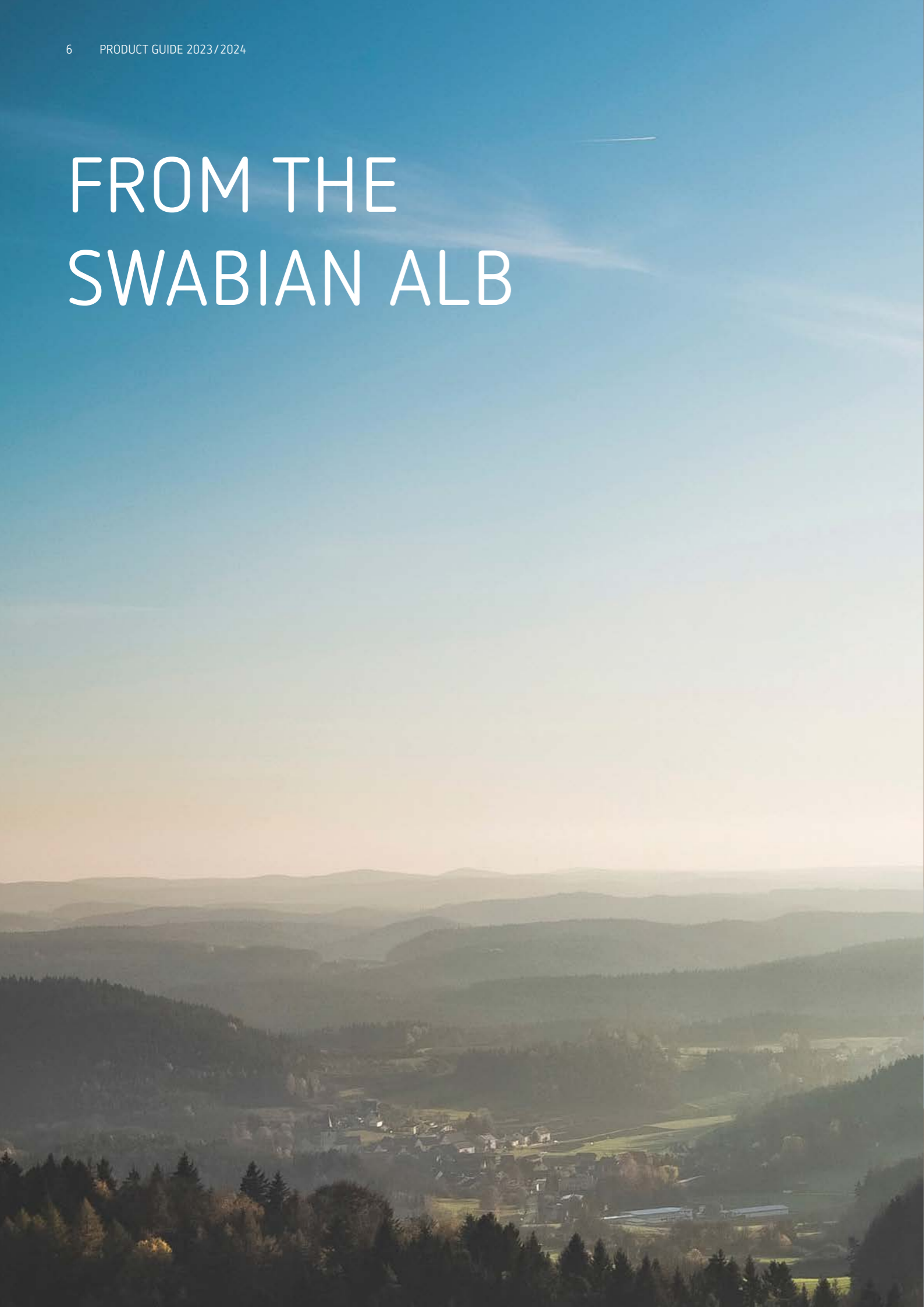

INTO THE WORKROOMS OF THIS WORLD



OUR STANDARD

As much as the moll products differ from each other, they all have one thing in common – the requirement to set a new benchmark in at least one of the following categories: function, design, or quality.

This explains why the name moll – in over 50 countries today – symbolizes first-class, robust workmanship, German manufacturing, an unmistakable corporate culture, and a well managed company with a clear idea. All of this has been upheld for 97 years.

moll.
FOR GENERATIONS.

Driven by curiosity and ambition.

OUR PROMISE

LONGEVITY

Longevity is one of our most important corporate values. Our promise is to produce furniture for generations:

1. Our products grow with you. From schoolchildren to adults – our products adapt ergonomically to their users
2. Additions allow the furniture to be flexibly adapted to changing needs.
3. For us, sustainability is not limited to the use of regional materials, but also means ensuring a high quality of workmanship, so that our products can be passed down through generations.
4. The timeless design of our products also ensures that they will be used for a very long time.
5. Our product promise includes a 5-year quality and after-sale guarantee.

OUR PROMISE

QUALITY

Tested ergonomics, safety and quality



AGR
"Aktion Gesunder Rücken" tests products for their ergonomic properties.



www.blauer-angel.de/uz38

The Blue Angel
The Blue Angel guarantees that products are produced with low emissions and meet high standards in terms of environmental health & utility properties being fulfilled.



GS-Gütesiegel
GS seal of approval ensures that the product complies with the requirements of the Product Safety Act (ProdSG), inspected and tested by the TÜV-Rheinland:
www.certipedia.com



Patents
moll develops all fittings themselves. Many of these innovations are protected by industrial property rights.



Made in Germany
moll products are developed in Gruibingen (DE) and manufactured according to high quality and safety standards.

Certified sustainability

FSC and PEFC Certification

To ensure the preservation of forests, we obtain our wood from a certified supply chain. This guarantees an ecological and socially acceptable and sustainable forestry.

CARB II

moll wood-based materials are CARB II compliant with stricter limit values than E1 E05 according to the current test method. This is for purpose-bound use according to the current state of knowledge, these are harmless.

Desk surfaces

All decorative surfaces are tested for abrasion resistance, stain resistance, scratch resistance and impact stress in accordance with EN 14322.

Our responsibility

In our production, we use mainly environmentally friendly, recyclable and separable materials. In this way we keep the CO2 footprint of our products as small as possible.

OUR PROMISE

INNOVATION

Healthy learning and working. What does ergonomics actually mean? Ergonomics means taking as much of the strain as possible off the body and not forcing it to adopt forced postures. This is especially important during the development phase for children.

How does ergonomic furniture work?

Ergonomic furniture has a preventive effect and protects against postural damage. It is flexible, functional and variable in its adjustment options and offers sufficient freedom of movement. Ergonomic furniture thus promotes a natural and upright sitting position, supports the spine and protects against postural damage in the long-term.

Our innovations are related to ergonomics, functionality and the optimization of the working and learning environment. We can ensure the long-lasting quality of our furniture through our patented functions. This means that our furniture is not only a long-term investment, but is also economically viable for our customers in the long-term.

PATENTED FUNCTIONS

INCLINE VARIANTS

Depending on the product, moll children's desks offer different levels of comfort regarding the inclination of the desk top. To ensure that nothing slips off the inclined desk top, all Winner and Champion versions

always come with a magnetic anti-slip device that can also be used as a ruler and magnifying glass. With the Joker, a simple anti-slip device is clamped to the edge of the table.



Joker tilting mechanism – latching position

The Joker table top can be easily tilted with the integrated spring support through 6 levels up to 16 degrees. At the same time, the latching prevents the plate from falling back unchecked.



Winner tilting mechanism – brake fitting

The table top can be continuously raised and lowered by up to 18 degrees to the desired angle using a lever under the table top. The adjustable fitting brake prevents the table top from falling back unbraked.



Champion – tilting mechanism with cable pull technology

The table top can be tilted gradually up to 20 degrees using a cable under the front edge of the table. The tilting mechanism with the patented safety clutch provides excellent pinch protection.

PATENTED FUNCTIONS

HEIGHT ADJUSTMENT VARIANTS

Height adjustment for children's desks is essential for us, which is why we hold three patents for height adjustment mechanisms:

Classic



Classic is characterized by a manual hook fitting and the tables can be correctly adapted to the users and utility channels in just a few simple steps. Height information printed on the base helps with correct adjustment.

10-stage hook fitting

Adjustment range: 53 - 82 cm

Height: 1.20 - 1.90 m

Comfort



Comfort is characterized by an easy-to-use cable spool that allows the table height to be continuously adjusted. The rope spool can be attached to the table base and removed again for safety after setting it correctly. Height information printed on the base helps with correct adjustment.

Infinitely variable height adjustment via cable pull

Adjustment range: 53-82 cm

Height: 1.20-1.90 m

express



Express has a large mechanical adjustment range. By pressing the control lever, the table can be adjusted faster than a person can get up - and all without electricity. The spring force of the table can be adjusted according to the table load, completely weight-neutral. The height adjustment can also be blocked.

Stepless quick height adjustment to sitting or standing height

Adjustment range: 69-114 cm, with height adapter: 79-124 cm

Height: 1.55-1.95m

FROM SMALL TO LARGE



FOR US



PRIME

PRIME is dedicated to homework.

Working from home is not only a socially relevant topic – it has been a core topic of our brand for years. With our products, we create the functional optimization of the requirements for concentrated learning and working at home.

Why?

Due to social and societal influences and changes such as people's decreasing attention span, poor posture over notebooks, the trend towards smaller living spaces, etc., the points of storage, ergonomics and the optimal use of the available space are becoming more important than ever.

If these points are taken into account in the study, children and adults can concentrate best. Therefore, the range of our product line PRIME, includes furniture for storage, with high adaptability and with the highest standards of ergonomics, in order to create an optimal workplace at home for children and adults.

The product line PRIME includes furniture for children and young people that leaves no wish unfulfilled in terms of quality, functionality, or durability.

The product line PRIME offers many options for individually configuring it upon purchase and also continuously adapting it to changing needs. When the table, chair and light are optimally tailored to the body, working method and space, the learning place becomes a favorite place - from the first class to graduation.

The product line PRIME includes three desk models: Joker, Winner and Champion as well as matching Additions and mobile pedestals and the two swivel chair models Maximo and Scooter. The rotating shelves Tower 56 and 64 create additional order and offer a lot of storage space next to the desk. The Mobilight and Flexlight workplace lights and a wide range of universal accessories round off the "PRIME" range.

DESKS



JOKER

JOKER FULL SIZE

01 Joker

Product features

- The frame is equipped with the Classic height adjustment.
- The runners are made of powder-coated steel and feature casters on the ends so that the desk can be moved easily.
- One-piece and easy-to-use, tiltable table top with rounded corners.

01 JOKER FULL SIZE

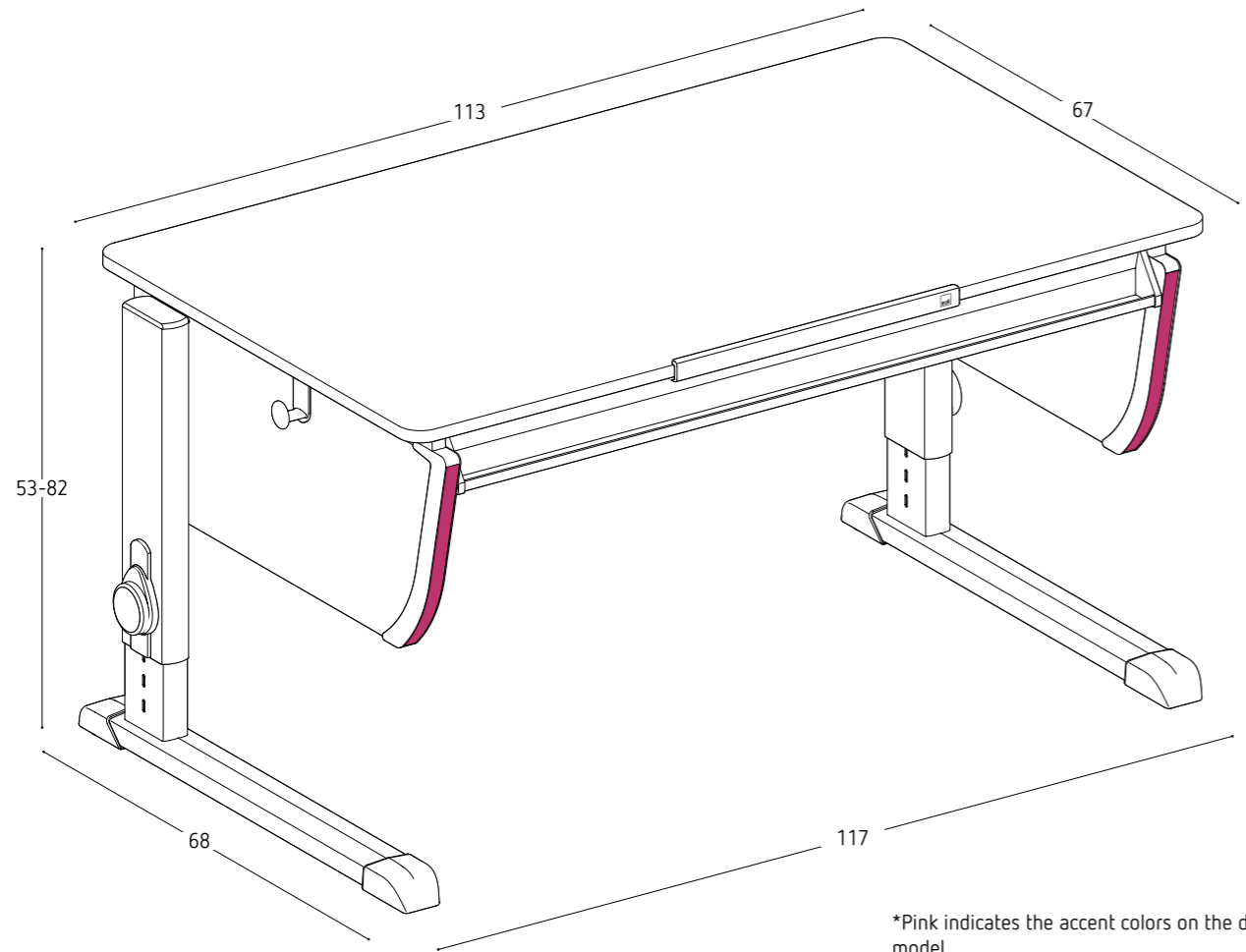

*Pink indicates the accent colors on the desk model

AT A GLANCE

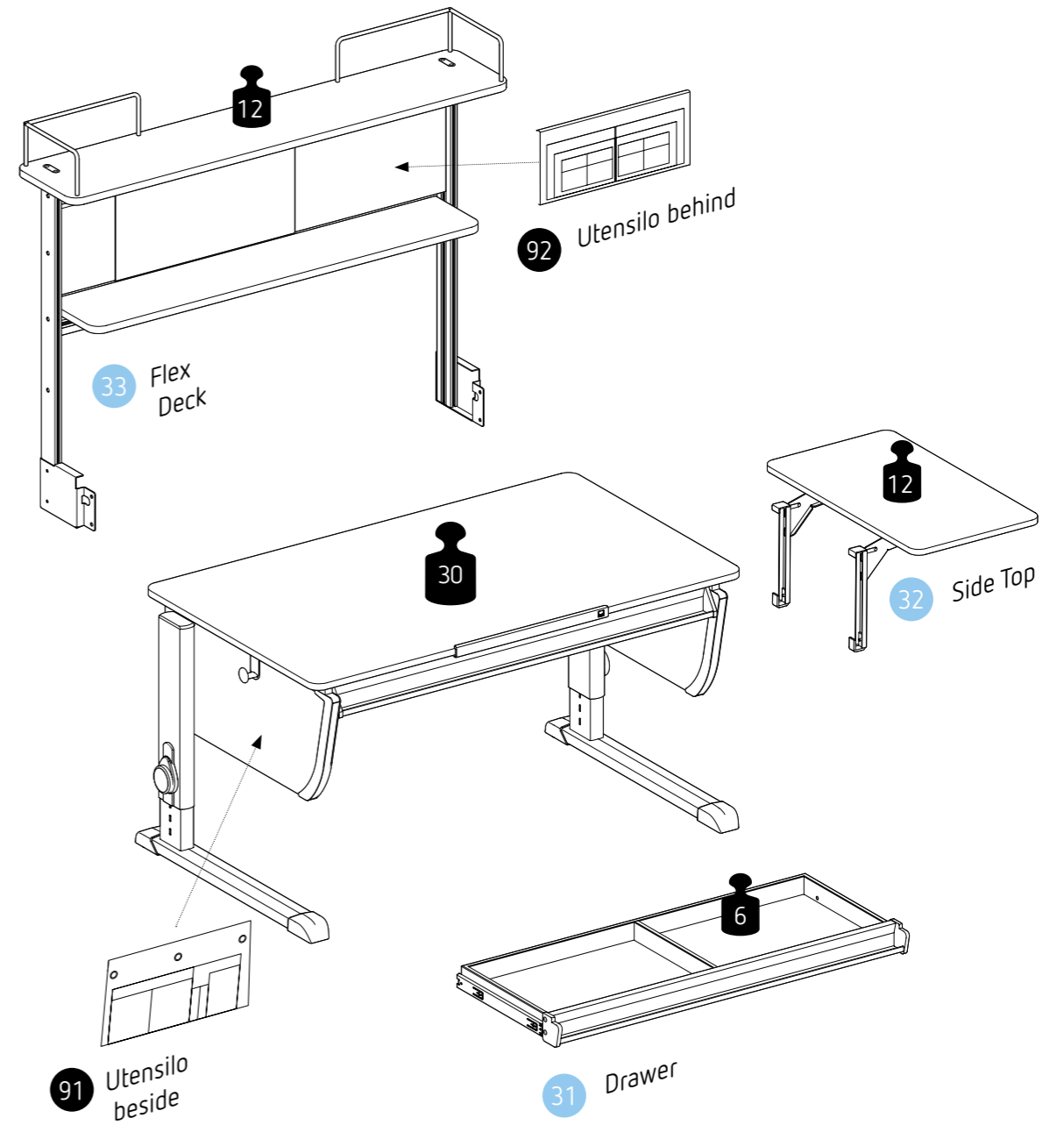

Tilting mechanism	Detent fitting, six steps (inclination: 16°)	
Height adjustment	02 Classic	
Accessories	<ul style="list-style-type: none"> • Basic book holder • Anti-slip barrier • Hook for bags 	
Color	White	
Accent colors classic*		

JOKER FULL SIZE ADDITIONS

31 Drawer



- Grey drawer with divider and handle profile
- Plenty of storage space without restricting legroom
- Can be added on at any time
- Loadable up to 6 kg
- Accessories: Orga-Set

⇔ 100 cm ⇨ 36 cm ⇦ 5 cm

32 Side Top



- Side horizontal shelf with rounded corners, especially recommended for tilted desktops
- Fastened via two height-adjustable supports on the side of the desk
- Retrofitting is possible on the left or right side
- Material: melamine-coated particle board
- Color: white
- Loadable up to 12 kg
- Accessories: Baskets SQ/RD

⇔ 40 cm ⇨ 67 cm

33 Flex Deck



- Multifunctional wall with two shelves and a magnetic board incl. four magnets – loadable up to 12 kg
- Additional shelf space above the desktop
- Fastens via two brackets on the back of the desk
- Two corner brackets made of aluminum (lateral support)
- Aluminum colored metal parts
- Color: white
- Material: melamine-coated particle board
- Retrofitting is possible
- Accessories: Utensilo behind, Baskets SQ/RD

⇔ 113 cm ⇨ 22 cm ⇦ 69 cm





WINNER

WINNER FULL SIZE • WINNER SPLIT

03 Winner

Product features

- Leg frame optionally available in the Classic or Comfort version.
- The runners are made of powder-coated die-cast aluminum and have castors in the rear part, so that the table can be easily moved.
- The desk is made of melamine coated derived timber material board.
- Optionally with a one-piece or divided tiltable table top.
- There is a colored strip and cap magazine in the handle profile.

03 WINNER FULL SIZE AND WINNER SPLIT

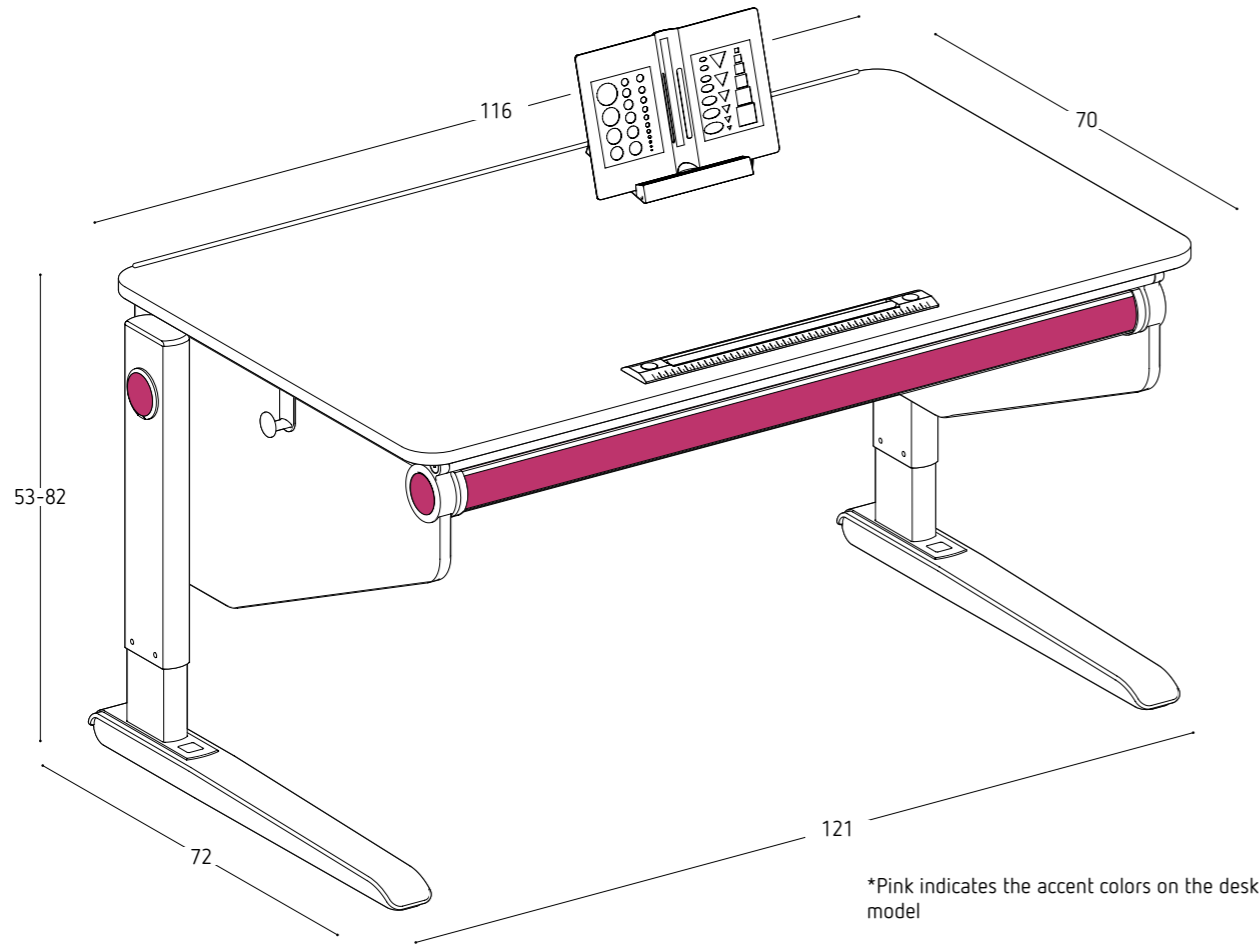

*Pink indicates the accent colors on the desk model

Desktop alternatives	<div style="display: flex; justify-content: space-around;"> <div style="text-align: center;"> <p>Winner Full Size</p> </div> <div style="text-align: center;"> <p>Winner Split</p> </div> </div>
Tilting mechanism	Brake fitting, stepless (inclination: 18°)
Height adjustment	04 ClassiC 05 omfort
Accessories	<ul style="list-style-type: none"> • Basic book holder • Magnetic-ruler • Hook for bags
Color	White, Maple-White and Oak.
Accent colors classic*	

AT A GLANCE

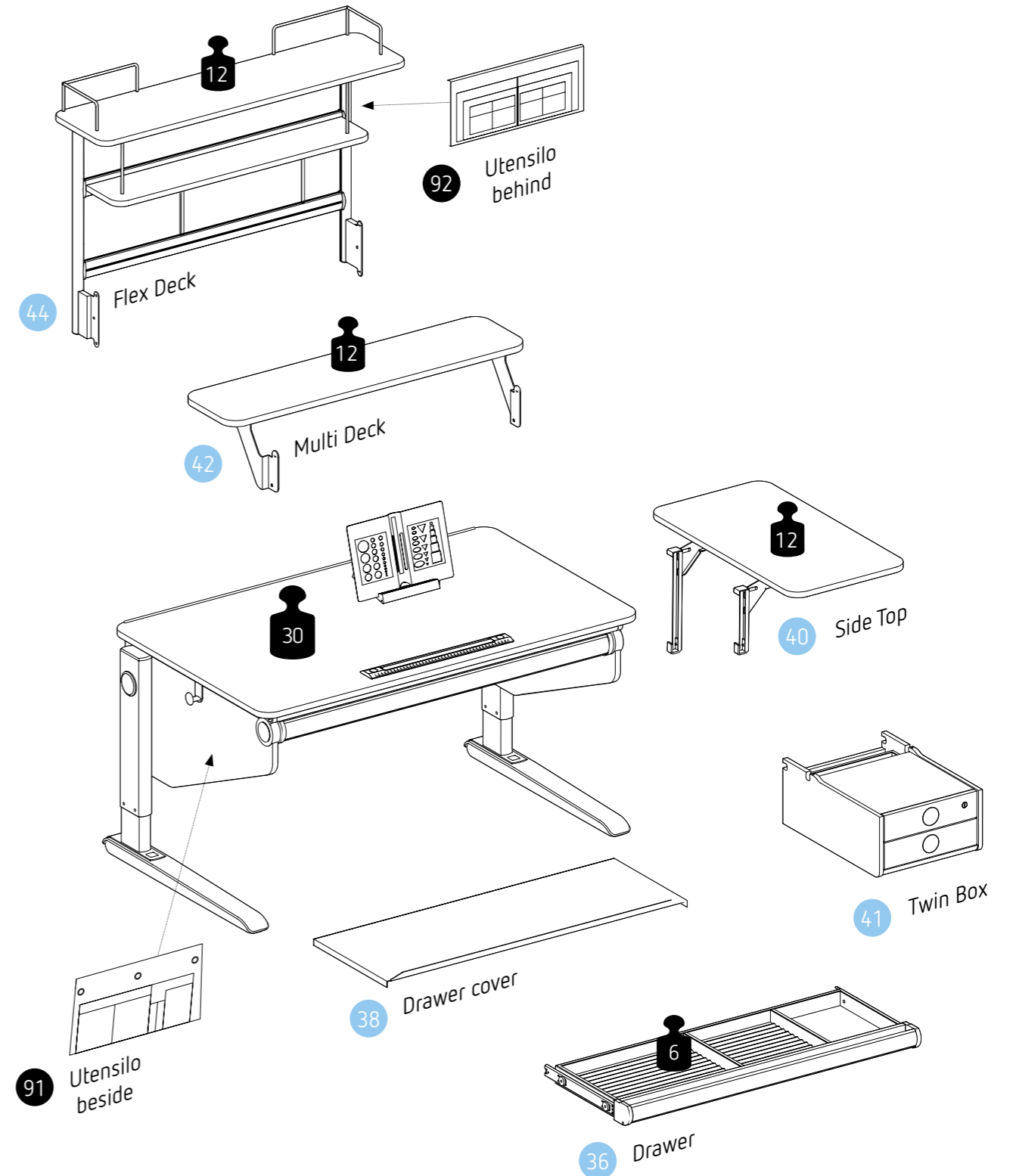

WINNER FULL SIZE AND WINNER SPLIT ADDITIONS

36 Drawer

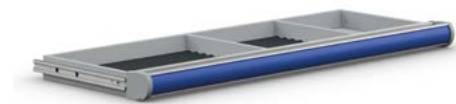

- Grey drawer with divider and aluminum handle profile
- Plenty of storage space without restricting legroom
- The drawer is divided by two dividers
- Inlays: corrugated foam
- Loadable up to 6 kg
- Retrofitting is possible
- Accessories: Orga-Set and drawer cover

⇔ 102 cm ⇨ 40 cm ⇩ 7 cm

38 Drawer cover



- The cover prevents the contents from getting dusty
- Provides privacy especially when the desktop is tilted
- Aluminum-colored cover, remains under the desktop when the drawer is pulled out.
- Consists of high-quality, lightweight aluminum composite material

⇔ 103 cm ⇨ 37 cm ⇩ 4 cm

40 Side Top



- Desk extension in width – loadable up to 12 kg
- Side shelf, even with desktop in inclined position
- Rounded corners
- Fastened via two supports on the side of the desk
- Can be mounted on right or left side
- Three colors: white, maple-white and oak
- Material: melamine coated derived timber material board
- Retrofitting is possible
- Accessories: Baskets SQ/RD

⇔ 38 cm ⇨ 70 cm

41 Twin Box



- Storage space underneath the desk body
- Can be mounted on the right or left side under the desktop
- Two drawers with self-closing mechanism, the upper drawer is lockable
- Six changeable color inlays for the recessed handles
- Three colors: white, maple-white and oak
- Material: Melamine resin coated derived timber material board
- Retrofitting is possible
- Accessories: Orga-Set, Color set Trend

⇔ 42 cm ⇨ 57 cm ⇩ 24 cm

42 Multi Deck



- Desktop extension in the desk depth – loadable up to 12 kg
- Level storage surface, even when the desktop is tilted
- Fastened by two metal supports on the back of the desk
- Aluminum skid extension on the desk feet, for extra stability
- Three colors: white, maple-white and oak
- Material: Melamine resin coated derived timber material board
- Retrofitting is possible
- Accessories: Baskets SQ/RD

⇔ 116 cm ⇨ 22 cm

44 Flex Deck



- Multifunctional wall with two shelves and one whiteboard/ magnetic board incl. four magnets – loadable up to 12 kg
- Additional shelf space behind and above the desktop
- Fastening via two brackets at the back of the desk
- Two corner brackets made of aluminum
- Three colors: white, maple-white and oak
- Material: Melamine resin coated derived timber material board and aluminum colored metal parts
- Retrofitting is possible
- Accessories: Utensilo behind, Baskets SQ/RD

⇔ 120 cm ⇨ 30 cm ⇩ 68 cm



WINNER

COMPACT



03 Winner Compact

Product features

- Leg frame optionally available in the Classic or Comfort version.
- The runners are made of powder-coated die-cast aluminum and have rollers at the rear part so that the table can be moved easily.
- The body consists of a melamine resin-coated wood-based panel.
- The Winner Compact is available in three selectable colors: white, maple white and oak.
- There is a colored strip/cap magazine in the grip profile.

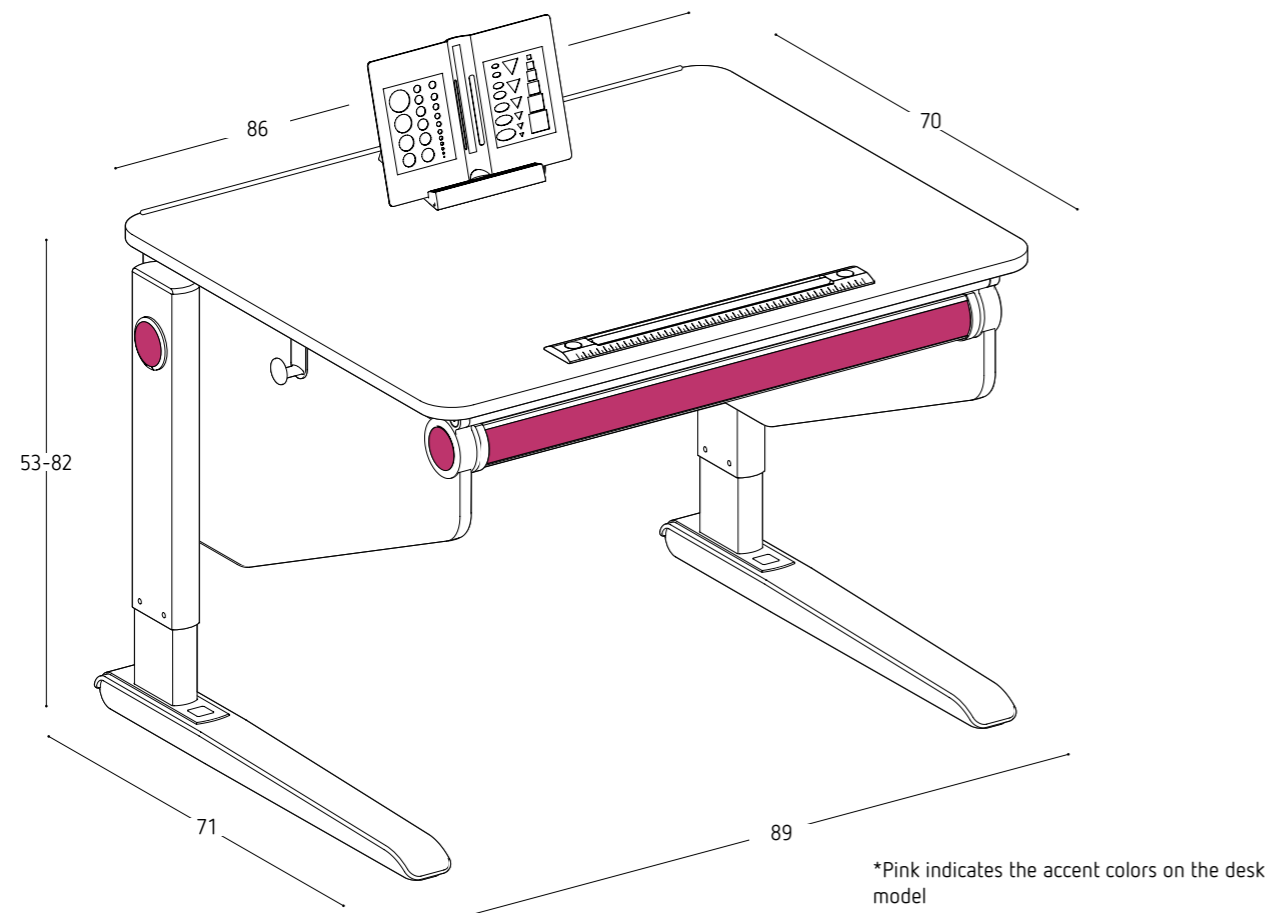
03 WINNER COMPACT

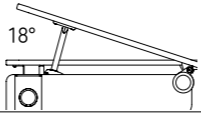

Tilting mechanism	Brake fitting, stepless (inclination: 18°)	
Height adjustment	04 Classic 05 Comfort	
Accessories	<ul style="list-style-type: none"> • Basic book-holder • Magnetic-ruler • Hook for bags 	
Color	White, Maple-White and Oak.	
Accent colors classic*		

AT A GLANCE

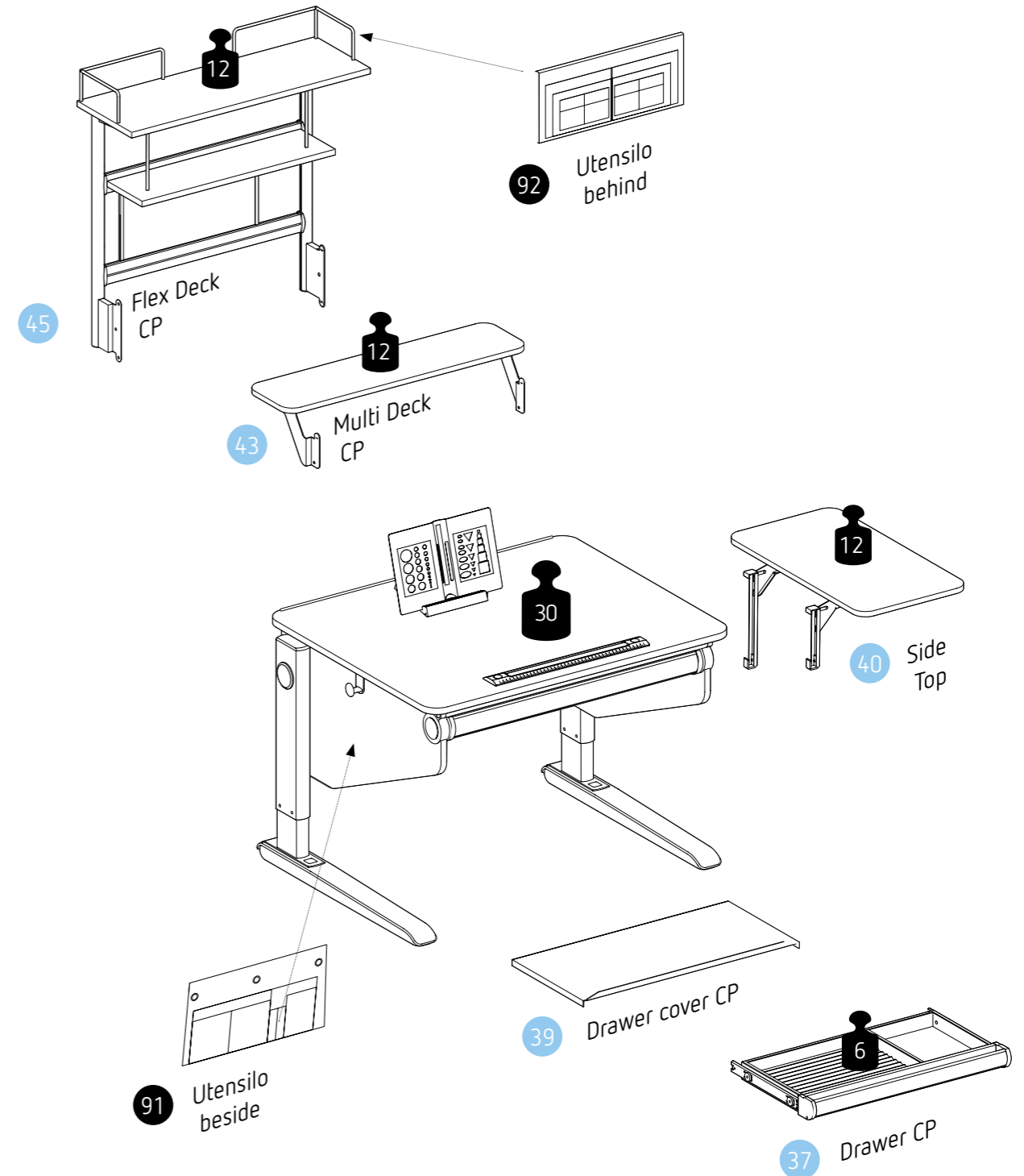

WINNER COMPACT (CP) ADDITIONS

37 Drawer CP

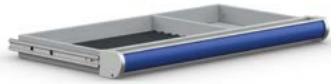

- Grey drawer with divider and aluminum handle profile
- Plenty of storage space without restricting legroom
- The drawer is divided by one divider
- Inlays: corrugated foam
- Loadable up to 6 kg
- Retrofitting is possible
- Accessories: Orga-Set and drawer cover

⇄ 72 cm ⇄ 40 cm ⇄ 7 cm

39 Drawer cover CP



- The cover prevents the contents from getting dusty
- Provides privacy especially when the desktop is tilted
- Aluminum-colored cover, remains under the desktop when the drawer is pulled out
- Consists of high-quality, lightweight aluminum composite material

⇄ 72 cm ⇄ 37 cm ⇄ 4 cm

40 Side Top



- Desk extension in width – loadable up to 12 kg
- Side shelf, even with desktop in tilted position
- Rounded corners
- Fastened via two height-adjustable supports on the side of the desk
- Can be mounted on right or left side
- Three colors: white, maple-white and oak
- Material: melamine coated derived timber material board
- Retrofitting is possible
- Accessories: Baskets SQ/RD

⇄ 38 cm ⇄ 70 cm

43 Multi Deck CP



- Desktop extension in the desk depth – loadable up to 12 kg
- Level storage surface, even when the desktop is tilted
- Fastened by two metal supports on the back of the desk
- Aluminum skid extension on the desk feet, for extra stability
- Three colors: white, maple-white and oak
- Material: Melamine resin coated derived timber material board
- Retrofitting is possible
- Accessories: Baskets SQ/RD

⇄ 86 cm ⇄ 22 cm

45 Flex Deck CP



- Multifunctional wall with two shelves and one whiteboard/ magnetic board incl. four magnets – loadable up to 12 kg
- Additional shelf space behind and above the desktop
- Fastening via two brackets at the back of the desk
- Two corner brackets made of aluminum
- Three colors: white, maple-white and oak
- Material: Melamine resin coated derived timber material board and aluminum colored metal parts
- Retrofitting is possible
- Accessories: Utensilo behind, Baskets SQ/RD

⇄ 90 cm ⇄ 30 cm ⇄ 68 cm



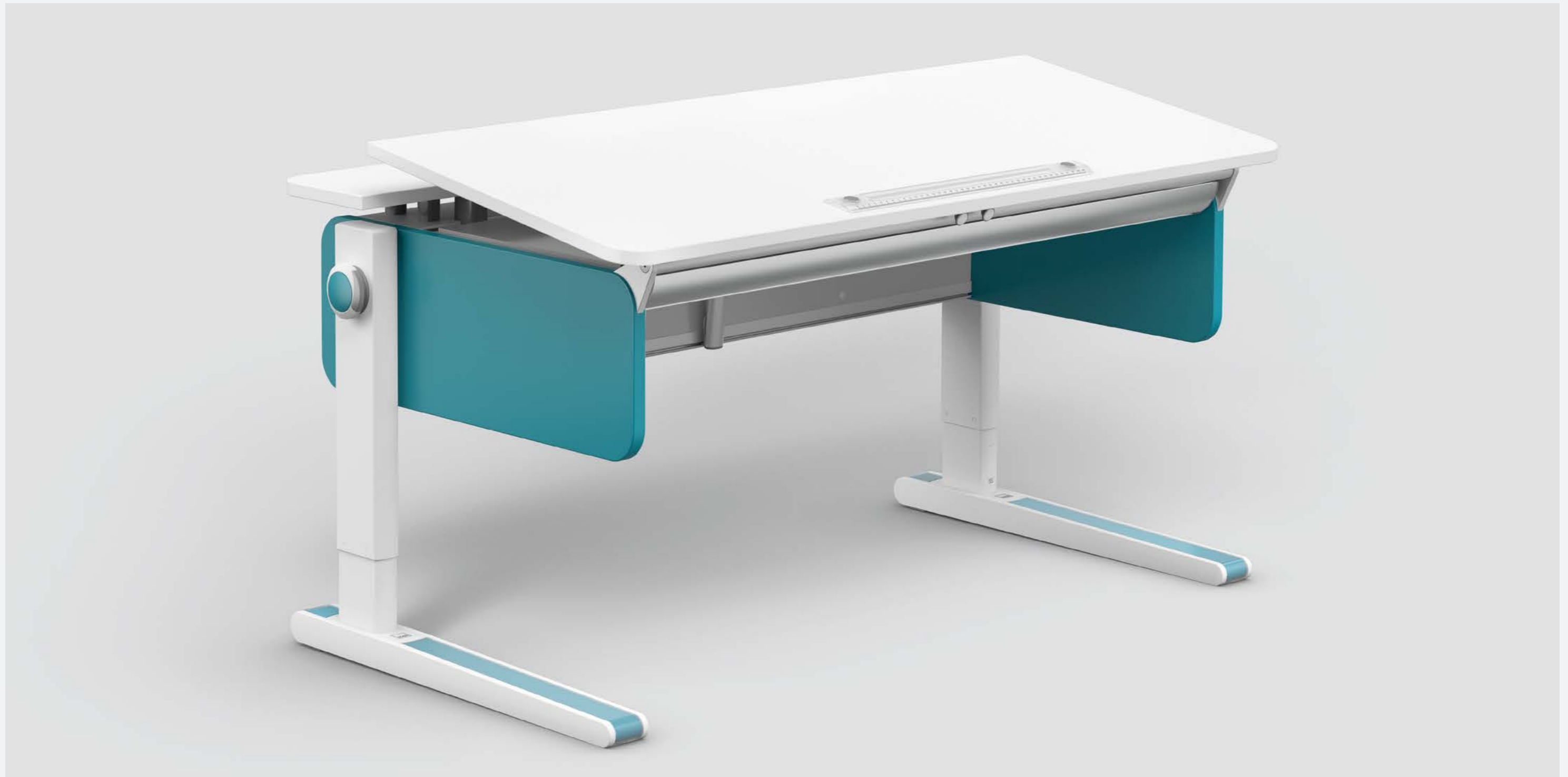

CHAMPION

FRONT UP • LEFT UP • RIGHT UP

06 Champion

Product features

- The Champion is available with Comfort height adjustment.
- The split tabletop is available for left-handed (Right Up) or right-handed users (Left Up).
- In order to move the desk easily, the skids in the rear part are equipped with rollers.
- The table is equipped with a cable duct. The felt cover is optional.

06 CHAMPION

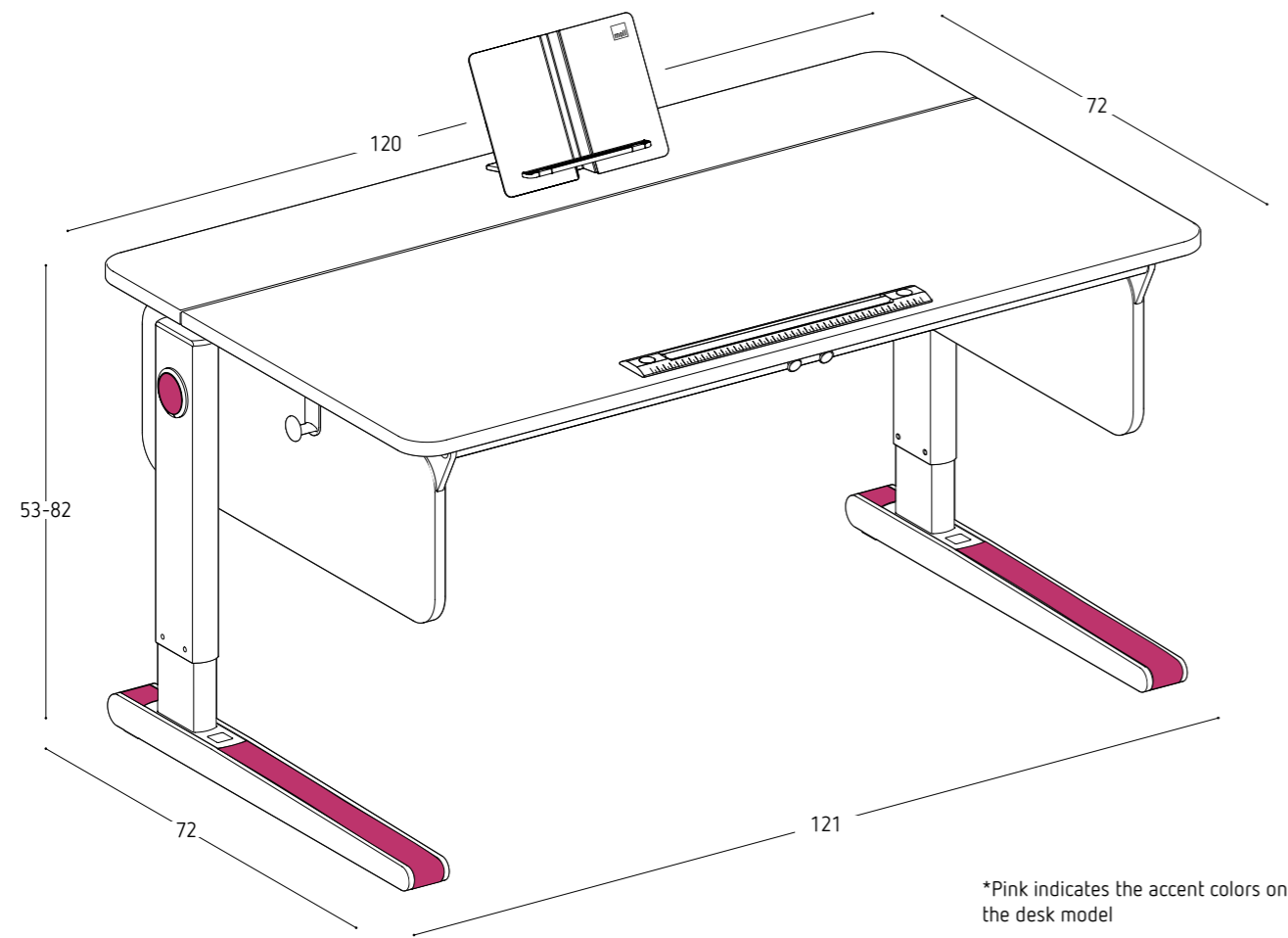

Desktop alternatives	
Tilting mechanism	Rope pull, stepless (inclination: 20°) Children can autonomously adjust the inclination.
Height adjustment	07 omfort
Accessories	<ul style="list-style-type: none"> • Design book-holder • Magnetic-ruler • Hook for bags
Color	White
Accent colors classic*	
Side panels colors	08

AT A GLANCE

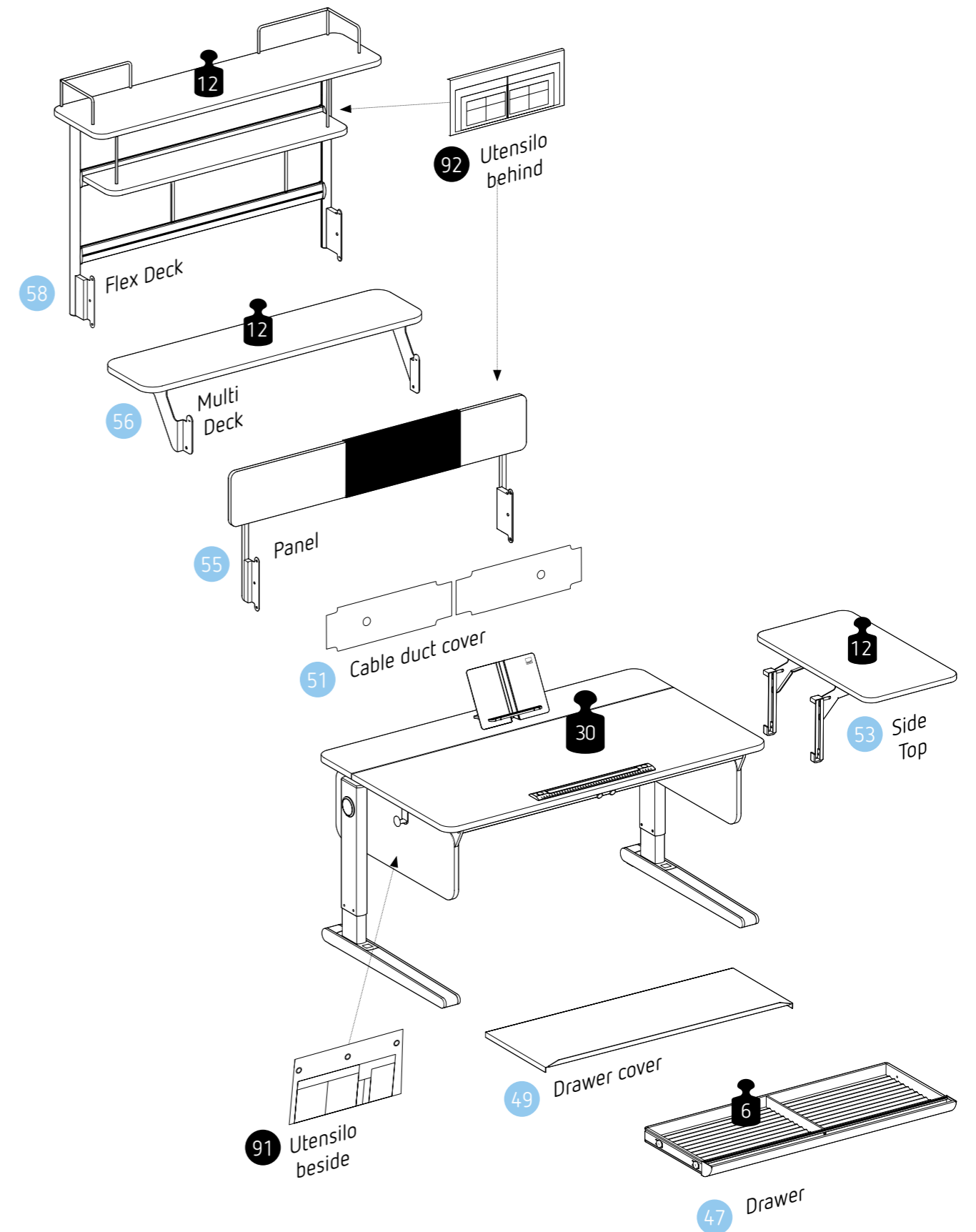



CHAMPION

SLIM



09 Champion Slim

Product features

- The Champion Slim, is the slim version of the Champion, with 10 cm less table depth, perfect for less space.
- It's available with the Comfort height adjustment.
- The divided tabletop allows you to have a surface to put things on despite the tilted position.
- In order to move the desk easily, the skids in the rear part are equipped with rollers.
- The table is equipped with a cable duct. The felt cover is optional.

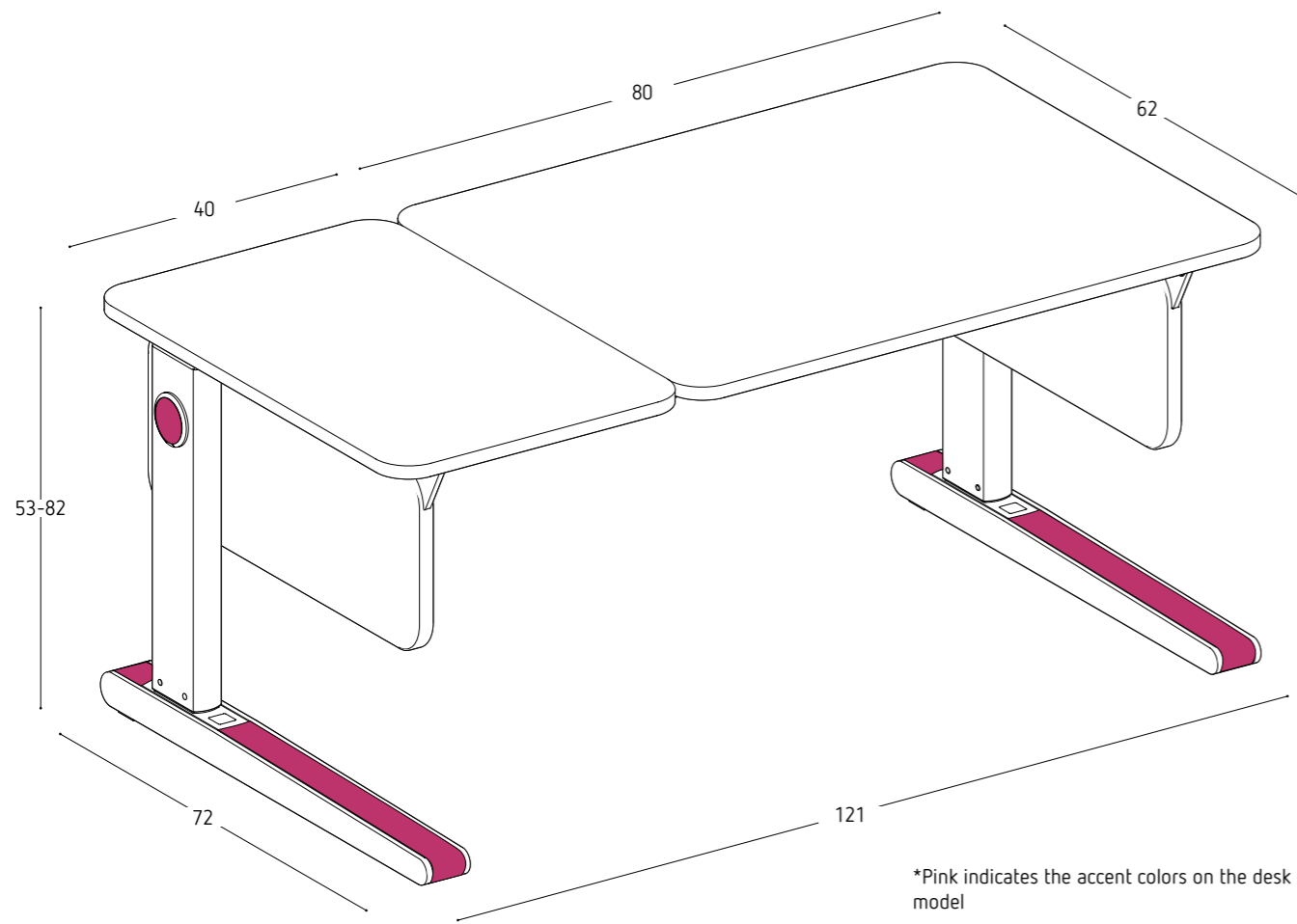
09 CHAMPION SLIM

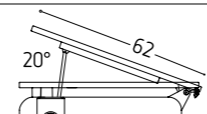

Tilting mechanism	Rope pull, stepless (inclination: 20°) Children can autonomously adjust the inclination.	
Height adjustment	07 omfort	
Accessories	<ul style="list-style-type: none"> • Design book-holder • Magnetic-ruler • Hook for bags 	
Color	White	
Accent colors classic*		
Side panels colors	10 	

AT A GLANCE

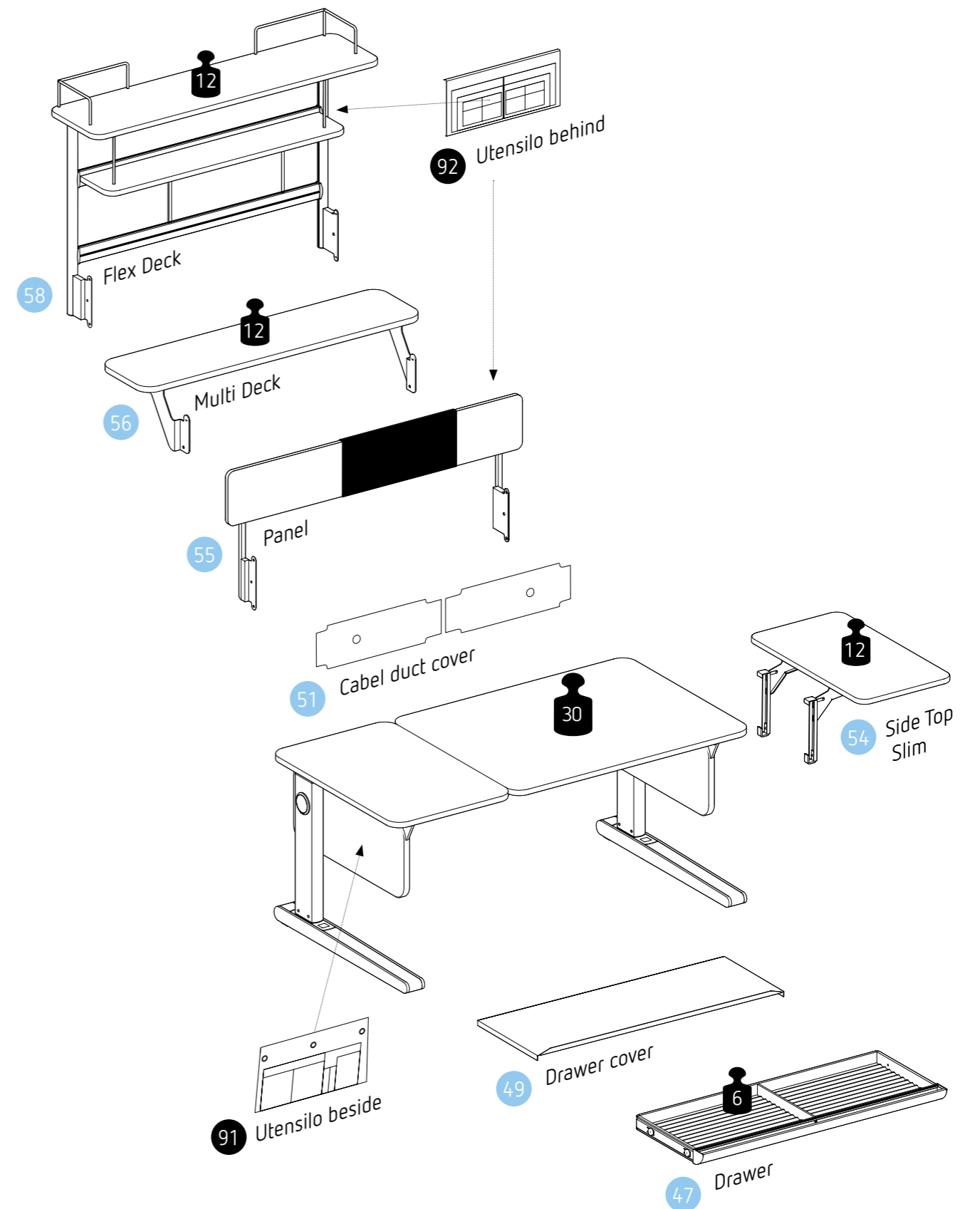

CHAMPION AND CHAMPION SLIM ADDITIONS

47 Drawer

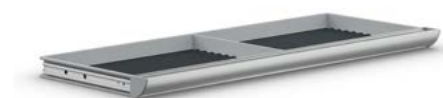

- High quality flat drawer made of aluminum profile
- Drawer size: two 297 x 420 mm sized compartments with a divider
- Plenty of storage space without restricting legroom
- Inlays: corrugated foam
- Retrofitting is possible
- Loadable up to 6 kg
- Accessories: Orga-Set and drawer cover

⇔ 103 cm ⇔ 42 cm ⇔ 6 cm

49 Drawer cover



- The cover prevents the contents from getting dusty
- Provides privacy especially when the desktop is tilted
- Aluminum-colored cover, remains under the desktop when the drawer is pulled out
- Consists of high-quality, lightweight aluminum composite material

⇔ 103 cm ⇔ 37 cm ⇔ 4 cm

51 Cable duct cover



- Two-piece felt cover for the cable duct
- With cable outlets
- Visibility and dust protection
- Retrofitting is possible

⇔ 102 cm ⇔ 16 cm

53 Side Top



- Lateral horizontal shelf with rounded corners, especially recommended for tilted desktop
- Fastened via two height-adjustable supports on the side
- Retrofitting possible on the left or right side
- Material: melamine coated derived timber material board
- Color: white
- Loadable up to 12 kg
- Accessories: Baskets SQ/RD

⇔ 40 cm ⇔ 72 cm

54 Side Top Slim



- Lateral horizontal shelf with rounded corners, especially recommended for tilted desktop
- Fastened by two height-adjustable supports on the side
- Retrofitting is possible on the left or right side
- Material: melamine coated derived timber material board
- Color: white
- Loadable up to 12 kg
- Accessories: Baskets SQ/RD

⇔ 40 cm ⇔ 62 cm

55 Panel



- Pinboard above the rear part of the desktop incl. four magnets
- Fastened via two supports at the back of the desk
- Material: melamine coated derived timber material board
- Color: white
- Retrofitting is possible
- Accessories: Utensilo behind

⇔ 120 cm ⇔ 6 cm ⇔ 20 cm

56 Multi Deck



- Desktop extension adheres to rear of desk – loadable up to 12 kg
- Level storage surface, even when the desktop is tilted
- Fastened via two height-adjustable supports on the back of the desk
- Rounded corners
- Aluminum skid extension on the desk feet provides extra stability
- Material: melamine coated derived timber material board
- Retrofitting is possible
- Accessories: Baskets SQ/RD

⇔ 120 cm ⇨ 22 cm

58 Flex Deck



- Multifunctional wall with two shelves and one whiteboard/ magnetic board incl. four magnets – loadable up to 12 kg
- Magnetic board can also be used as a whiteboard
- Additional shelf space above the desktop
- Rounded shelves
- Two aluminum corner brackets on the upper shelf (lateral support)
- Fastened by two supports on the back of the desk
- Material: melamine coated derived timber material board and aluminium profile
- Color: white
- Retrofitting is possible
- Accessories: Utensilo behind, Baskets SQ/RD

⇔ 120 cm ⇨ 30 cm ⇨ 68 cm





CHAMPION

COMPACT

06 Champion Compact

Product features

The Champion Compact combines all the plus points of the Champion for the smallest of spaces. Thanks to its compact dimensions, it is the ideal solution for small children's rooms. But the "little one" can also be different: With two side tops or a flex deck, it grows in height and width. This makes the Champion Compact a highly flexible alternative.

06 CHAMPION COMPACT (CP)

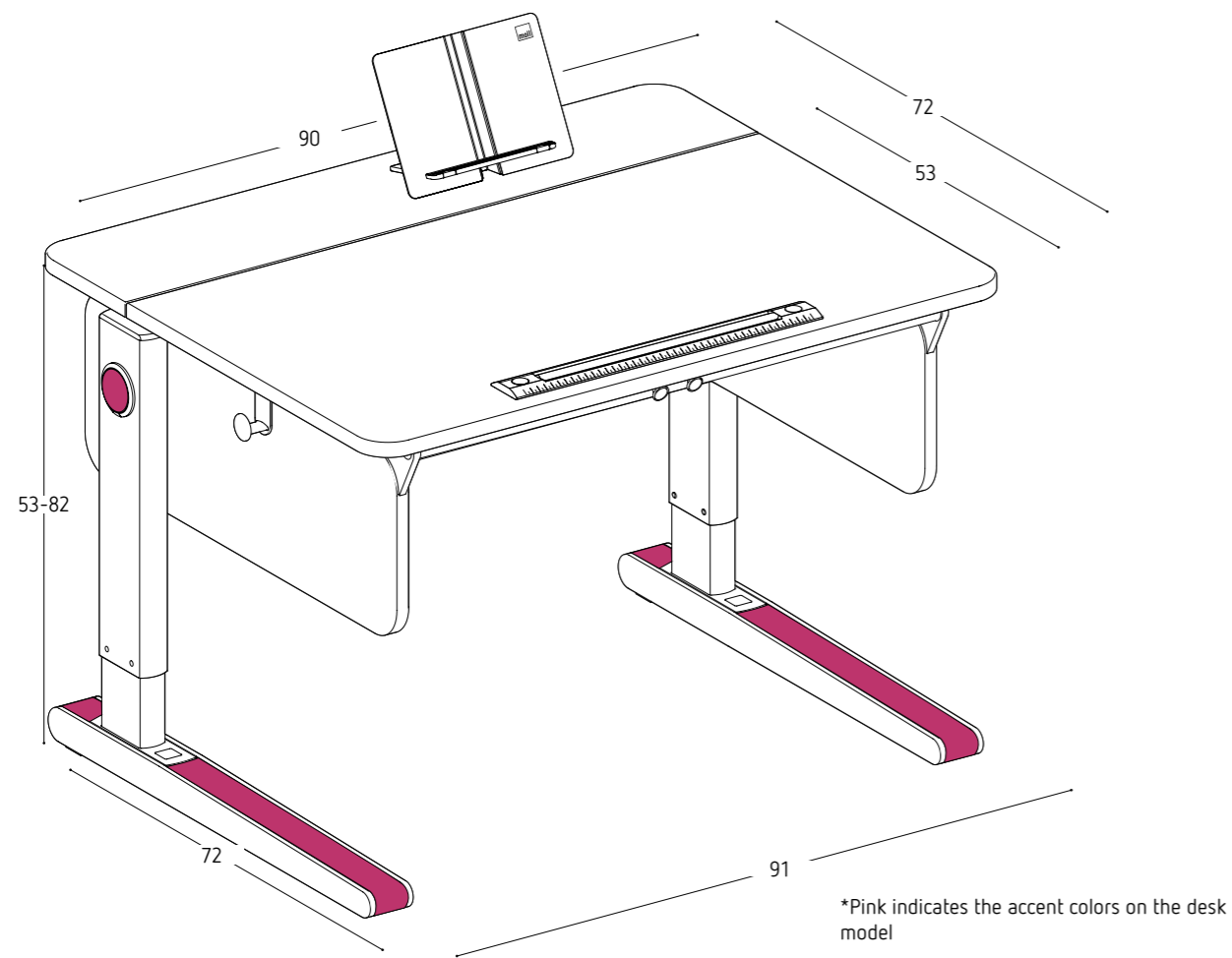

Tilting mechanism	Rope pull, stepless (inclination: 20°) Children can autonomously adjust the inclination.	
Height adjustment	07 omfort	
Accessories	<ul style="list-style-type: none"> • Design book-holder • Magnetic-ruler • Hook for bags 	
Color	White	
Accent colors classic*		
Side panels colors	10	

AT A GLANCE

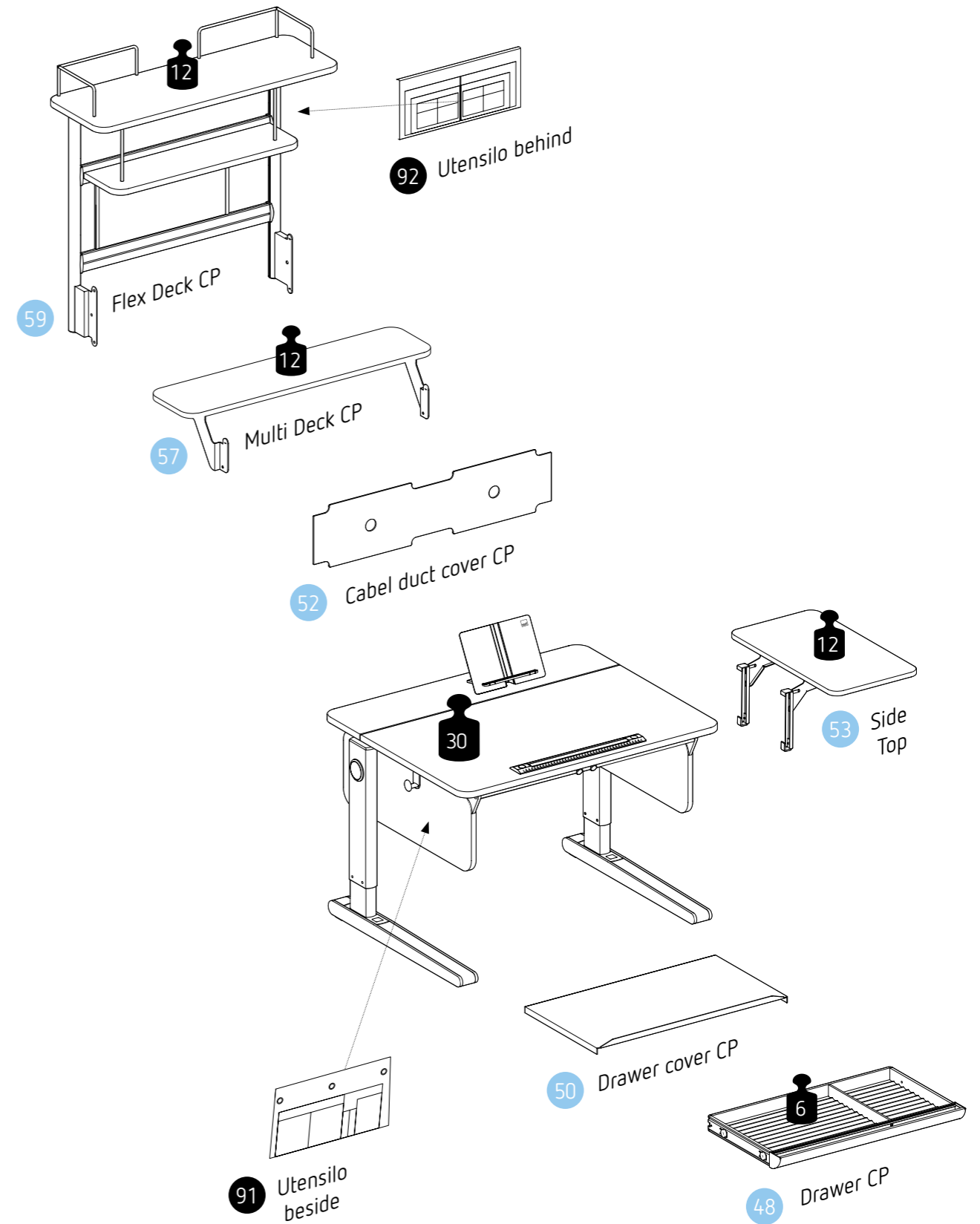



CHAMPION

EXPRESS COMPACT





11 Champion Express Compact

Product features

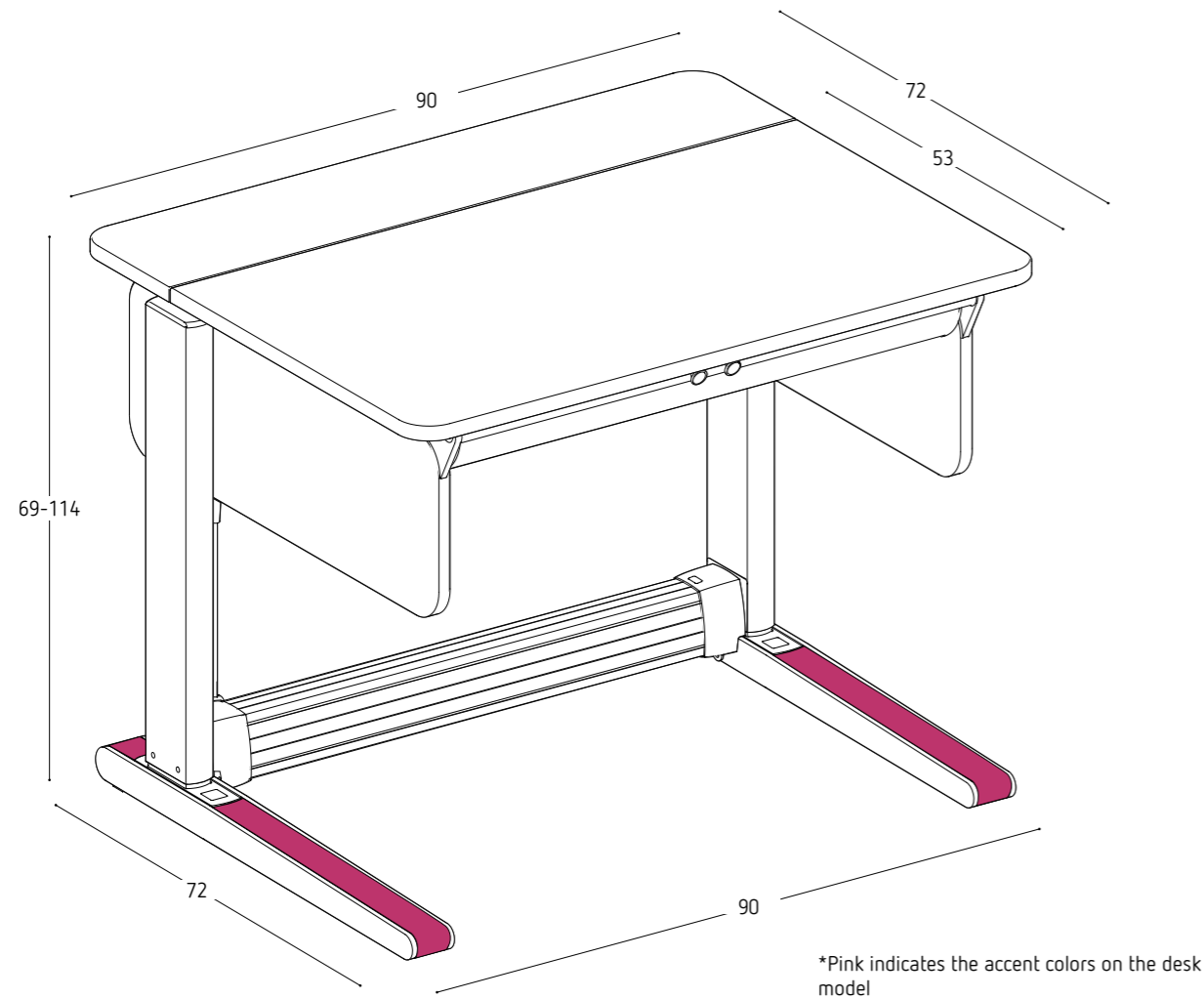
With the Champion Express Compact you can change from sitting to standing height in less than a second: With the ultra-fast Express height adjustment integrated in the base frame, the position can be changed at any time and without any effort.

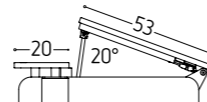
11 CHAMPION EXPRESS COMPACT (ECP)



Tilting mechanism	Rope pull, stepless (inclination: 20°) Children can autonomously adjust the inclination.	
Height adjustment		
Accessories	<ul style="list-style-type: none"> • Design book-holder • Magnetic-ruler • Hook for bags 	
Color	White	
Accent colors classic*		
Side panels colors	10 	

AT A GLANCE

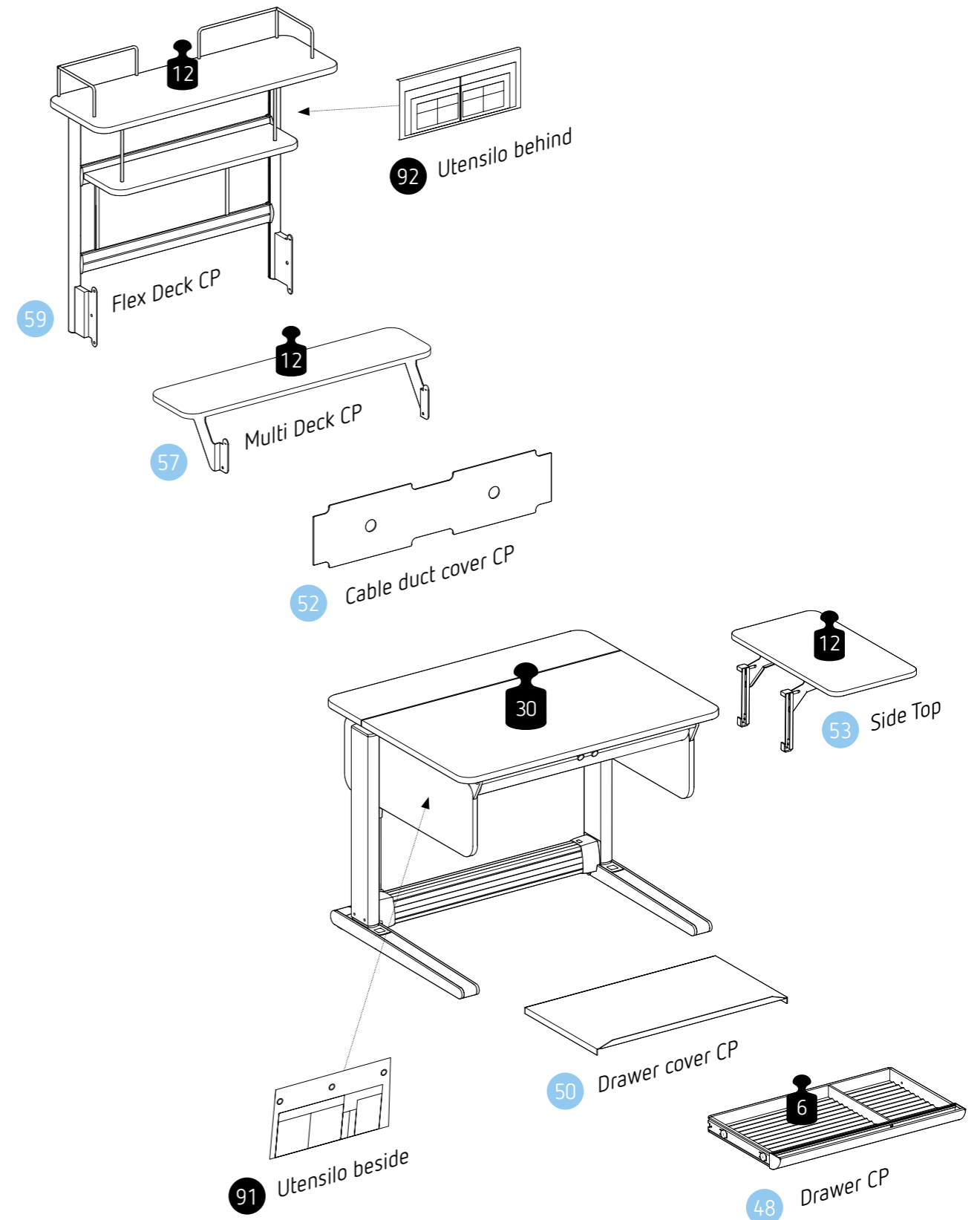

CHAMPION COMPACT AND EXPRESS COMPACT ADDITIONS

48 Drawer CP/ECP



- High quality flat drawer made of aluminum profile
- Drawer size: one 297 x 420 mm sized compartment and one 210 x 297 mm compartment with a divider
- Plenty of storage space without restricting legroom
- Inlays: corrugated foam
- Retrofitting is possible
- Loadable up to 6 kg
- Accessories: Orga-Set and drawer cover

⇄ 72 cm ⇄ 42 cm ⇄ 6 cm

50 Drawer cover CP/ECP



- The cover prevents the contents from getting dusty
- Provides privacy especially when the desktop is tilted
- Aluminum-colored cover, remains under the desktop when the drawer is pulled out
- Consists of high-quality, lightweight aluminum composite material

⇄ 72 cm ⇄ 37 cm ⇄ 4 cm

52 Cable duct cover CP/ECP



- Felt cover for the cable duct
- With cable outlets
- Visibility and dust protection
- Retrofitting is possible

60 Height adapter ECP



- Desk elevation by an additional 10 cm for a body height of 1.85 meters
 - Desk height with height adapter: 79-124 cm (instead of 69-114 cm)
- Attention: Only for Champion Express Compact**

53 Side Top



- Lateral horizontal shelf with rounded corners, especially recommended for tilted desktop
- Fastened by two height-adjustable supports on the side
- Retrofitting is possible on the left or right side
- Material: melamine coated derived timber material board
- Color: white
- Loadable up to 12 kg
- Accessories: Baskets SQ/RD

⇄ 40 cm ⇄ 72 cm

57 Multi Deck CP/ECP



- Desktop extension in the desk depth - loadable up to 12 kg
- Level storage surface, even when the desktop is tilted
- Fastened via two supports on the back of the desk
- Rounded corners
- Aluminum skid extension on the desk feet provide extra stability
- Material: melamine coated derived timber material board
- Retrofitting is possible
- Accessories: Baskets SQ/RD

⇄ 90 cm ⇄ 30 cm

59 Flex Deck CP/ECP



- Multifunctional wall with two shelves and one whiteboard/magnetic board incl. four magnets – loadable up to 12 kg
- Magnetic board can also be used as a whiteboard
- Additional shelf space above the desktop, rounded shelves
- Two aluminum corner brackets on the upper shelf (lateral support)
- Fastened via two supports on the back of the desk
- Material: melamine coated derived timber material board and aluminium profile
- Color: white
- Retrofitting is possible
- Accessories: Utensilo behind, Baskets SQ/RD

⇄ 90 cm ⇄ 30 cm ⇄ 68 cm

MATERIALS, COLORS AND PATTERNS TABLES & ADDITIONS

1 Melamine coated wood-based panel:
moll furniture is made of wood-based panels in accordance with EN 312 and EN 14322. The Formaldehyde class CARB II is complied with, which is based on more stringent limit values than the E1 test method according to EN 120. As per the current state of knowledge, no damage to health or adverse effects will occur.

2 Painted MDF wood-based panels:
Sides consist of MDF wood-based panels, with primer foil: surface varnished with UV-curing Acrylic lacquer system. This was produced on a water-base and is therefore particularly environmentally friendly.

3 Solid oak or Walnut oiled:
Solid wood as a natural raw material from sustainable forestry (FSC certified). Tested according to EN 13353 and EN 13 017-2.

Blue Angel
The Blue Angel guarantees that products are produced with low emissions and meet high environmental, health & usage properties are met: www.blauer-engel.de/uz38

Made in Germany
moll products are developed in Germany and manufactured according to high quality and safety standards.

FSC and PEFC certification
Confirms and certifies the responsible handling of the raw material wood. To ensure the preservation of our forests, we source our wood from a certified supply chain. This guarantees ecological and socially acceptable, and sustainable forestry.

CARB II
moll wood-based materials are CARB II compliant with more stringent limits than E1 E05 according to the current test method. This is not harmful to the health when used, according to current knowledge.

Desk surfaces
All decorative surfaces are tested for abrasion resistance to stains, scratching and impact stress in accordance with EN 14322.

Our responsibility
In our moll production we use primarily environmentally friendly materials. On the one hand, we want to keep the CO2 footprint of our products as small as possible. On the other hand, we wish to use materials that can be recycled and/or reused.

JOKER CORPUS

WHITE¹

WINNER CORPUS

WHITE¹MAPLE-WHITE¹OAK¹

CHAMPION TABLE PLATE

WHITE¹

CHAMPION SIDE COLORS

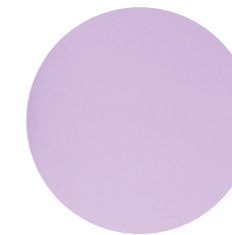
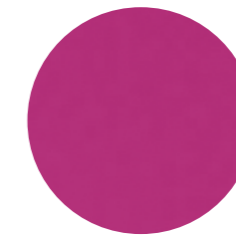
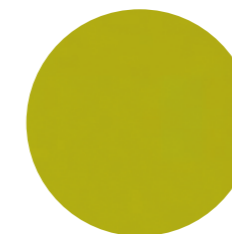
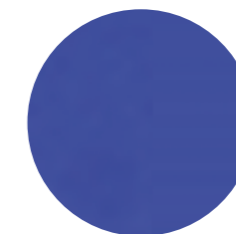
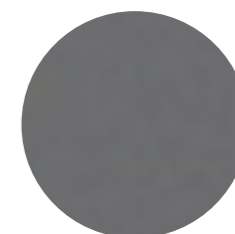
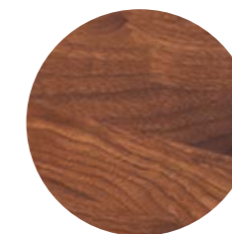
WHITE¹LAVENDER²PINK²TEAL²LIME²BLUE²ANTHRACITE²OAK³WALNUT³



"I've never tried that before,
so I'm totally confident I can do it."

Pippi Langstrumpf



DESK CHAIRS



MAXIMO

17 Maximo

Product features

- The seat depth and height as well as the backrest can be adjusted independently of each other.
- Maximum load up to 80 kg.
- Suitable for a height of about 1.10 up to 1.85 meters.
- A shock absorber under the seat and an in itself elastic seat surface offer the crucial: "More seat dynamics and comfort!"
- The five-star, extra-wide base and an integrated turn stop (lockable pivot bearing) ensure particular stability and safety.
- The double castors are slightly braked for the highest security requirements and are suitable for both hard and soft floor coverings.

17 MAXIMO

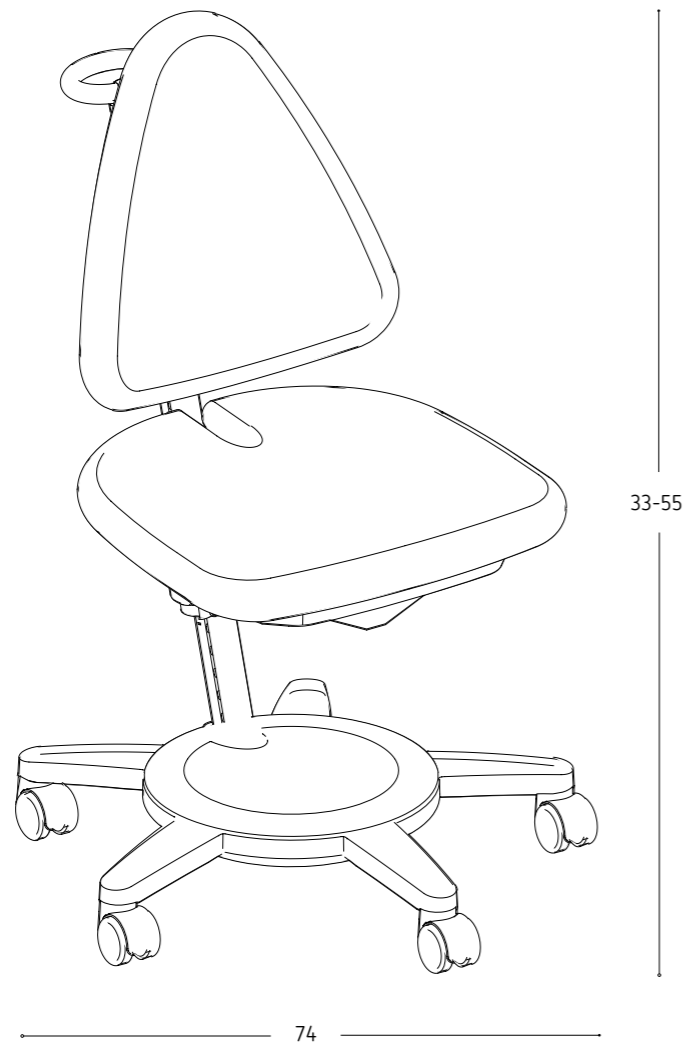

AT A GLANCE

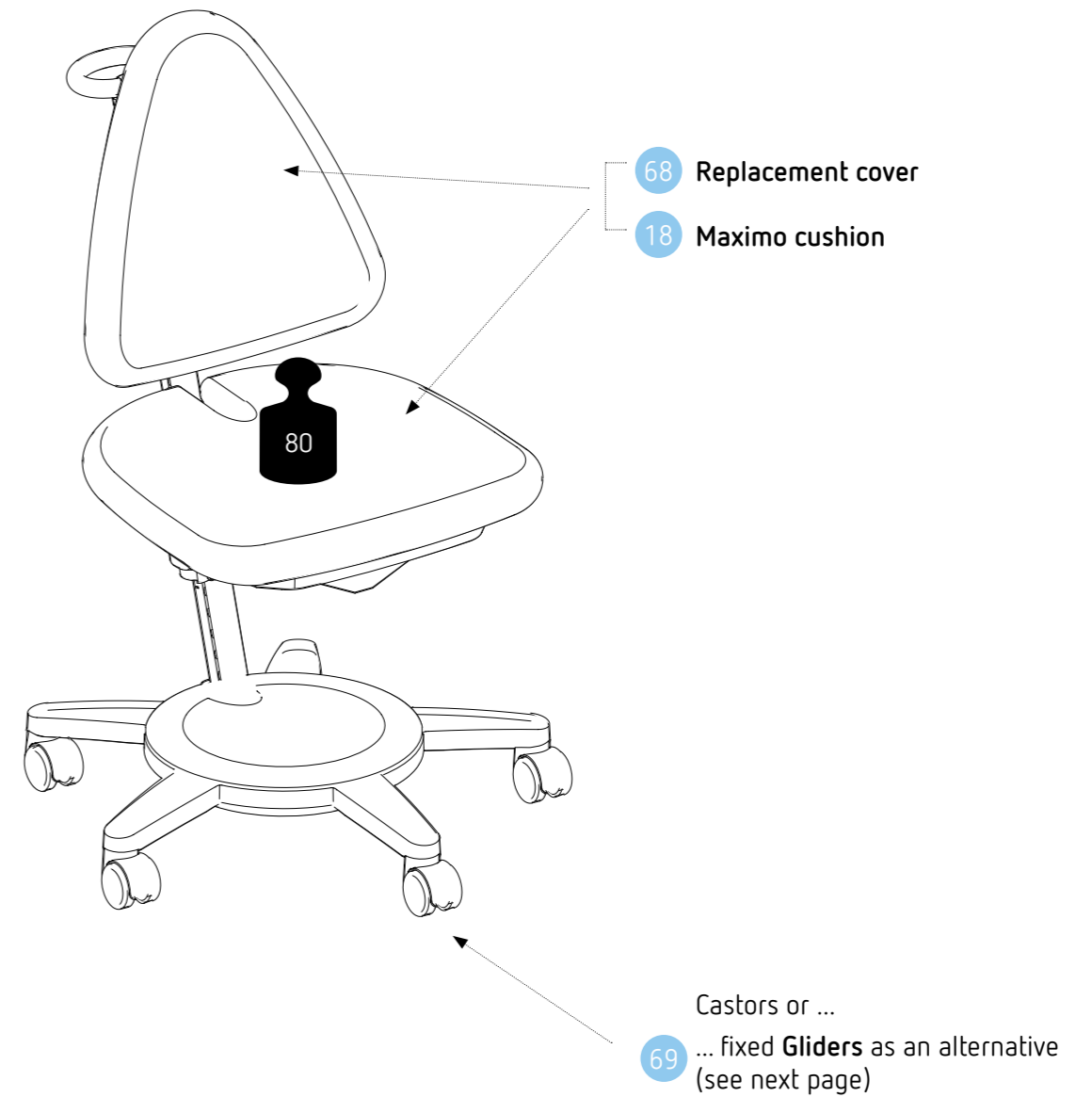

Frame color	White or grey
Integrated	Two secret compartments under the seat
Additions	Replacment cover, glider
Adjustment range	<ul style="list-style-type: none"> • Seat height 28-55 cm • Seat depth 29-42 cm • Backrest height 73-104 cm

MAXIMO ADDITIONS

18 Maximo cushion

68 Replacement cover



- Three different fabric qualities
- Available in 15 different colors
- Highly durable and easy to clean
- The seat and back cushion can be easily changed
- The covers can be replaced at any time

Please follow the care instructions on the label!

69 Glider



- Fixed gliders as a replacement for castors.
- With the gliders, the chair height is reduced by 3 cm – this makes it possible for smaller children to sit with an ergonomically correct posture
- Retrofitting is possible

⇔ 3,5 cm





SCOOTER

19 Scooter

Product features

- The hard-wearing mesh covering guarantees a high level of breathability and promotes a comfortable and ergonomic sitting posture through possible weight shifts.
- The swivel chair can be loaded up to a maximum of 90 kg.
- Suitable for a height of about 1.20 up to 1.95 m.
- Seat height/depth and backrest height can be adjusted intuitively with control levers.
- Easily exchangeable back and seat cushions.
- Six-armed, extra-wide base made of fiberglass-reinforced plastic ensures stability and security.
- The double castors are designed for maximum security set slightly braked and suitable for both hard and soft floor coverings.

19 SCOOTER

AT A GLANCE

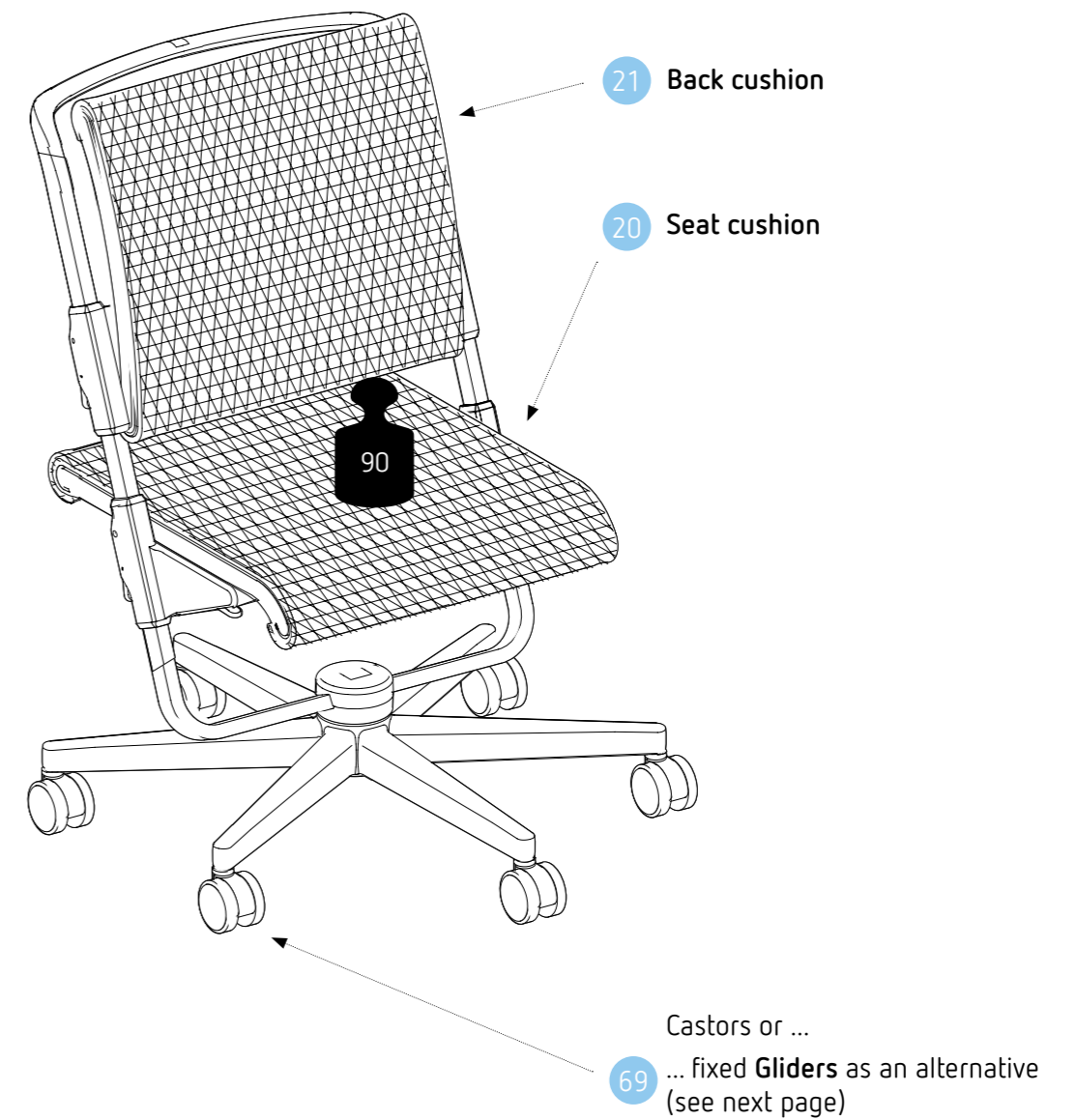
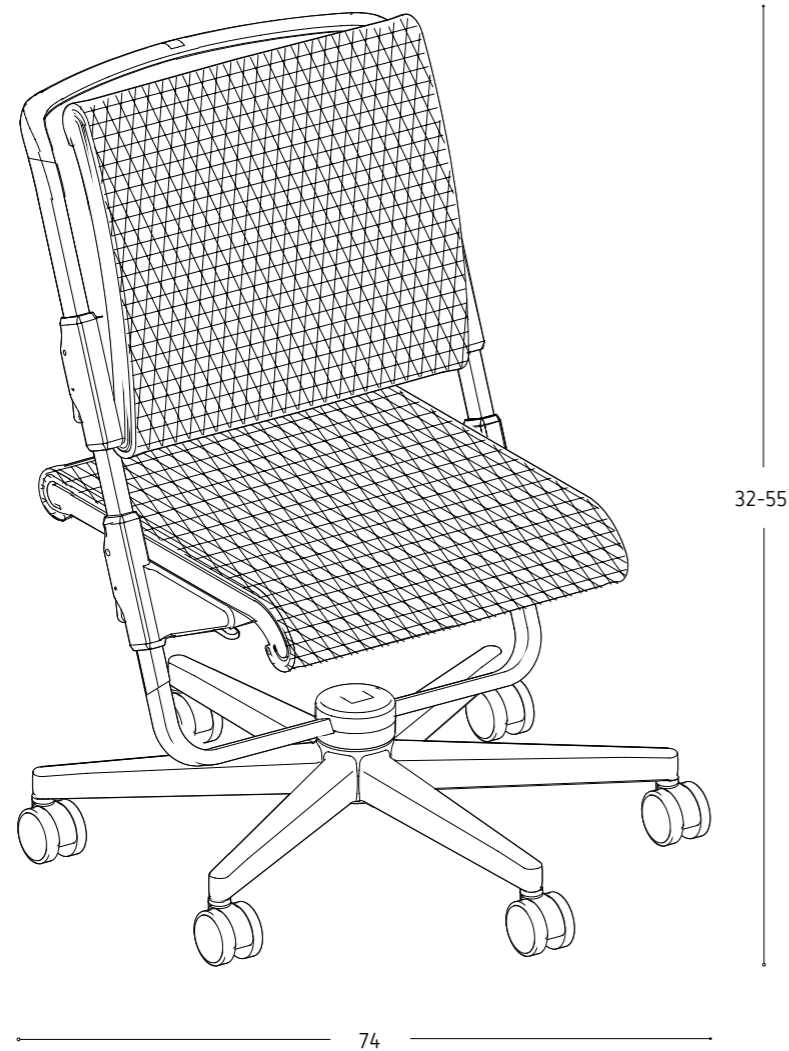

Frame Color	White or Grey
Additions	Seat and back cushions, glider
Adjustment range	<ul style="list-style-type: none"> • Seat height 30-53 cm • Seat depth 28-42 cm • Backrest height 71-92 cm

SCOOTER ADDITIONS

20 Seat cushion

21 Back cushion



- Three different fabric qualities
- Available in 15 different colors
- Highly durable and easy to clean
- Easy to change seat and back cushion, with 4 press studs

Please follow the care instructions on the label!

⇔ 44 cm ⇨ 67 cm ⌀ 1 cm ⇔ 44 cm ⇨ 56 cm ⌀ 1 cm

69 Glider



- Fixed gliders as a replacement for castors.
- With the gliders, the chair height is reduced by 3 cm – this makes it possible for smaller children to sit with an ergonomically correct posture
- Retrofitting is possible

⇔ 3,5 cm



MATERIALS, COLORS AND PATTERNS CHAIRS & SEAT CUSHIONS

Composition and care of cover fabrics

Composition Classic 1 + Motif 1

Material: 100% flame retardant polyester
Does not contain dyes or heavy metals
Made from 100% recycled polyester
Environmentally friendly and tested for harmful substances according to Oeko-Tex® Standard 100
Weight 260 g/m² ± 5%
Abrasion resistance: 50,000 Martindale / 37,500 Wyzenbeek
Fire safety BS 476 Part 7 Class/BS 476 Part 7 Class 0
Lightfastness: 6 (ISO 105 - B02:2013) according to BS 2543:1995/2004 tested
Rubbing color fastness: Wet 4, Dry: 4, tested according to BS 2543:1995/2004

Composition Trend 2

Material: chenille fabric, 96%PES, 4%NY
Contains no dyes or heavy metals
Environmentally friendly and tested for harmful substances according to Oeko-Tex® Standard 100
Weight: 574 g/m² ± 5%
Abrasion resistance: 45,000 Martindale / 33,500 Wyzenbeek
Fire safety: BS 5852 passed
Lightfastness: 4-5 (ISO 105 - B02:2013), tested according to BS 2543:1995/2004
Rubbing color fastness: Wet: 5, Dry: 5, tested according to BS 2543:1995/2004

Composition mesh cover Scooter 5

Material: 100% elastomer polyester
Abrasion resistance: 50.000 Martindale / 37.500 Wyzenbeek
Lightfastness: 5
Rubbing color fastness: Wet 5, Dry: 4

Composition Utensilo 6

Material: durable polyester fabric

Cleaning 1 2 5 6

Vacuum regularly
When dirty, wipe with a damp cloth
Please follow the care instructions on the label 1 2 6

COVER FABRICS MOTIFS¹



GALAXY



LOTTA



WONDERLAND

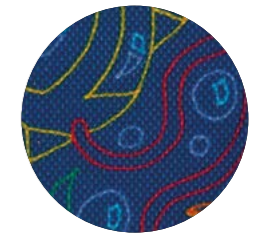

SUBMARINE

COVER FABRICS TREND²

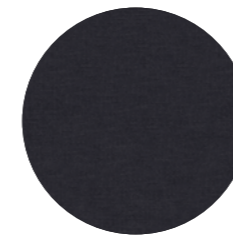

ANTHRACITE

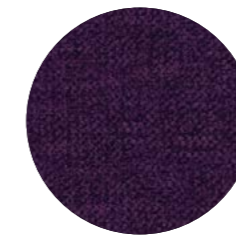

NIGHTSHADE

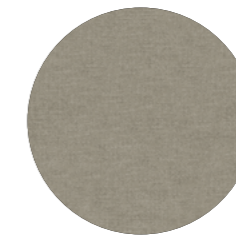

KHAKI

COVER FABRICS CLASSIC¹

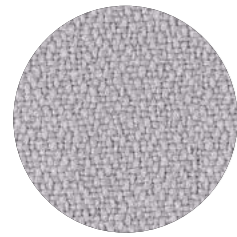

GREY



LIME

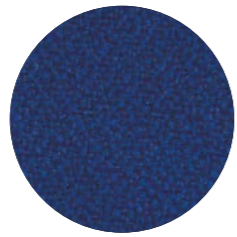

BLUE

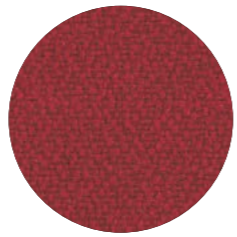

RED



PINK

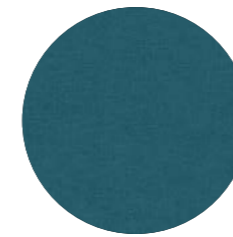

TEAL

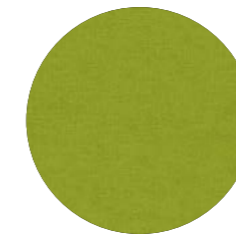

LIME

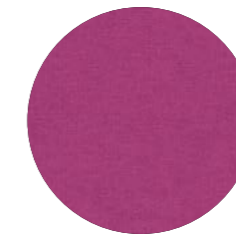

MAGNOLIA

MESH COVER FOR THE CHAIR SCOOTER⁵

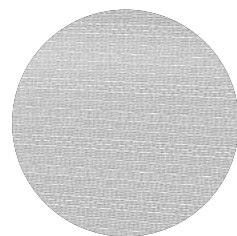

SILVER

UTENSILO COLORS

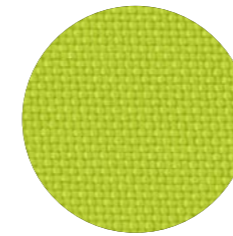

GREEN

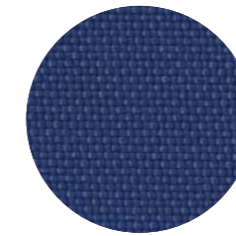

BLUE

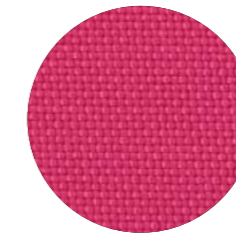

PINK

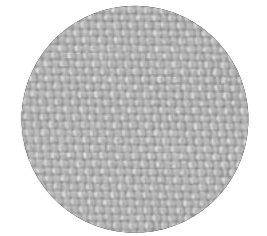

GREY

STORAGE FURNITURE



PRO

14 Pro

Product features

- The top of the three self-closing drawers is ideal for writing/art supplies. It's lockable and has a hidden secret compartment!
- The bottom two drawers in DIN format A3 offer generous storage space.
- All corners are rounded and therefore reduce the risk of injury.

- Three colors available to match the Joker and for all Winner variants (white, maple white, oak).
- Four smooth-running double castors (two lockable) make the container mobile.



CUBIC

15 Cubic

Product features

- The Cubic has three self-closing drawers.
- The top drawer is lockable and has a removable secret compartment.
- The lower two drawers in DIN A3 format offer generous storage space.
- The mobile container with its white decor is identical in design to the Champion.
- Four smooth-running double castors (two lockable) make the container mobile.



CUBICMAX

16 Cubicmax

Product features

- The Cubicmax offers even more storage space thanks to an additional drawer and a shelf attachment with two shelves variable in height and depth.
- The two shelves can be used either as one large shelf or as two smaller ones. This creates three divided compartments in the rear part of the shelf, with more height available in the front area, for folders, for example.
- Four smooth-running double castors (two lockable) make the container mobile.

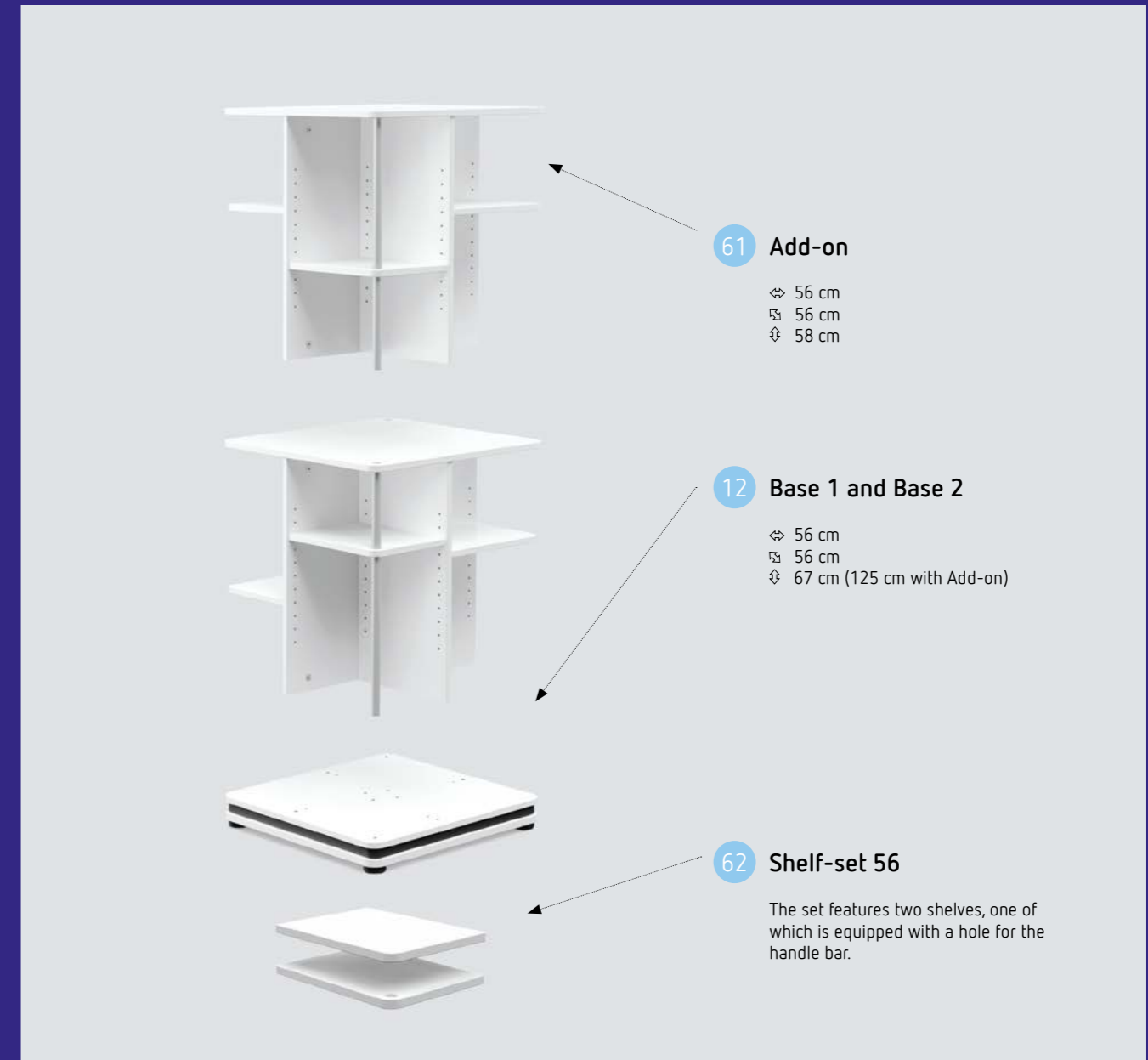

61 Add-on
 ⇄ 56 cm
 ⌘ 56 cm
 ⚡ 58 cm

12 Base 1 and Base 2
 ⇄ 56 cm
 ⌘ 56 cm
 ⚡ 67 cm (125 cm with Add-on)

62 Shelf-set 56
 The set features two shelves, one of which is equipped with a hole for the handle bar.

TOWER 56

12 Tower 56 (square shaped revolving shelf)

Product features

The basic structure of the Tower 56 consists of base 1 and 2. Further additions, such as the Tower 56 Add-on and Shelf-set or the Baskets SQ 70 and 130 complete the Tower.

- With its low-noise pivot bearing, the Tower 56 can be rotated around its own axis and enables convenient access to every shelf on the tower.

- Integrated handle bars made of aluminum make turning easier, they also secure the contents of the shelf and are an elegant design feature.
- The Tower 56 has a soft anti-trap protection on the rotating floor.
- Adjustable feet allow the rotating shelf to stand securely, even on uneven floors.

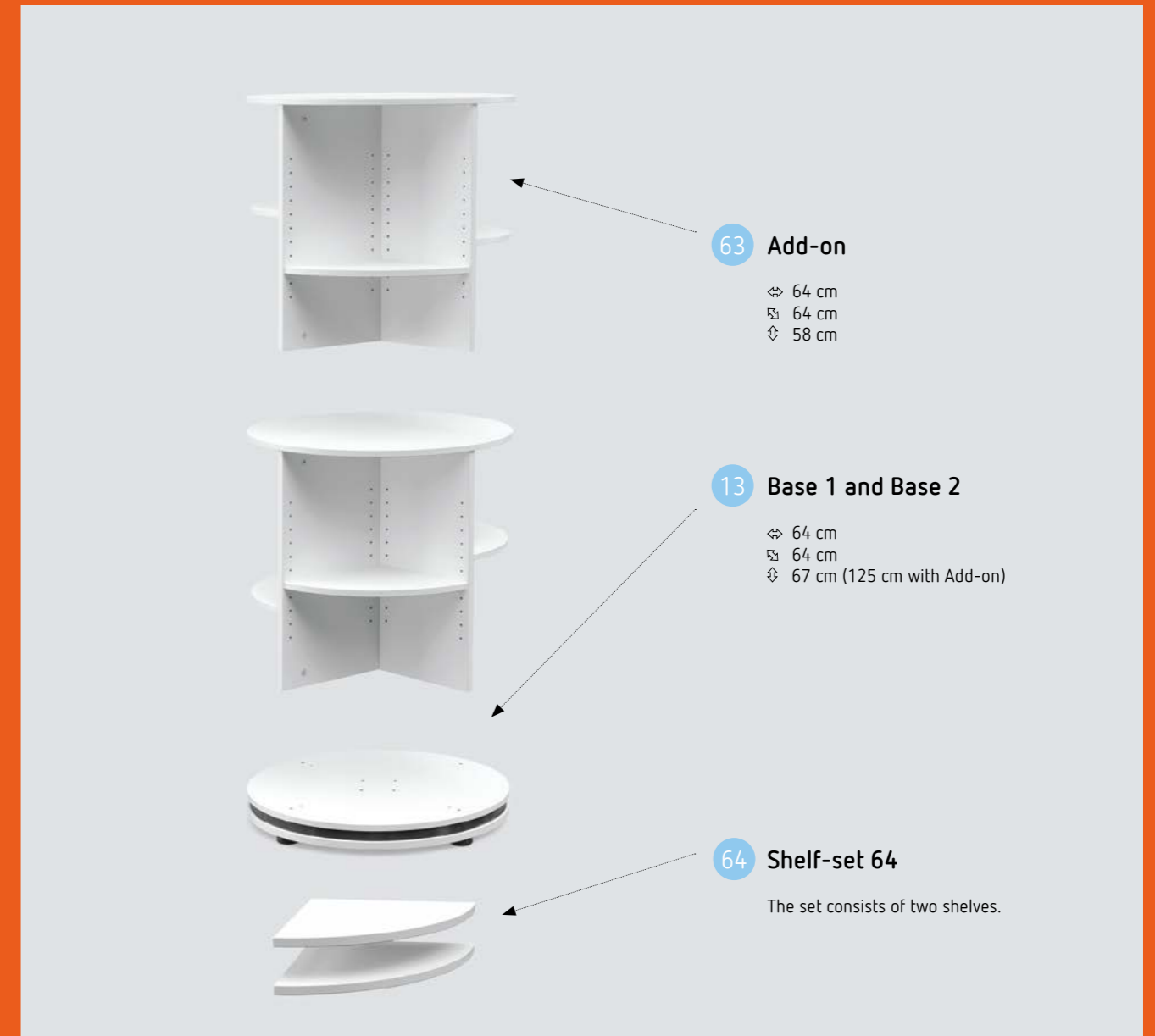

TOWER 64

13 Tower 64 (circular shaped revolving shelf)

Product features

The basic structure of Tower 64 consists of Base 1 and Base 2. Further additions, such as the Tower 64 Add-on and Shelf-set or the Baskets RD 70 and 130 complete the Tower.

- The Tower 64 rotates on its own axis with its low-noise swivel bearing and allow convenient access to any shelf in the tower.

- The shelves can be mounted at any height.
- The Tower 64 can be expanded in height thanks to its practical modular design – basic shelf and add-on shelves.
- The Tower 64 has an ABS profile for a secure clamping protection on the rotating shelf.
- Adjustable feet allow the rotating shelf to stand securely, even on uneven floors.



ACCESSORIES

ACCESSORIES

85 Anti-slip barrier



- Transparent anti-slip device for tilted desktops
- Included with purchase of a Joker Desk
- Exclusively compatible with the Joker

⇄ 45 cm ⇄ 6 cm ⇄ 1 cm

80 Cable-Butler



- Practical helper for desk work with a computer or laptop
- Clips to all desktops
- Ensures security and order of all cables on the desk
- Cables remain within reach, without falling off the desk

⇄ 10 cm ⇄ 5 cm ⇄ 8 cm

83 Basic book-holder



- Transparent book holder with school timetable, stencil and magnifying glass
- Included with Joker and all Winner variants.
- Brackets allow the book holder to be held in place even when the desktop is at an angle.

⇄ 33 cm ⇄ 13 cm ⇄ 24 cm

84 Design book-holder



- Foldable book holder
- Included in all Champion variants
- Two fold-out clamps hold the book or folder in place
- Retaining brackets make it possible to hang the book holder even with the desktop at an angle

⇄ 32 cm ⇄ 15 cm ⇄ 23 cm

86 Magnetic-ruler



- Transparent anti-slip device with ruler & reading magnifier
- Included with all Winner and Champion models
- Two invisible magnetic inlays hold the anti-slip device in place when the desktop is tilted.
- Exclusively compatible with Winner and Champion

⇄ 45 cm ⇄ 6 cm ⇄ 1 cm

82 Orga-Set



- Fits in all moll drawers, mobile containers, the Tower 56 and in the Tower 64
- Writing and painting utensils are always tidy in the drawer and can be placed on the desk in one set
- With fold-out tape dispenser and sharpener

⇄ 23 cm ⇄ 17 cm ⇄ 5 cm

81 Hook for bags

- To hang on one of the side panels of the desk
- The school bag always hangs neatly in its place
- Comes with every Joker, Winner and Champion desk

⇄ 5 cm ⇄ 3 cm ⇄ 5 cm

88 Desk Pads

- Six different motifs (from left to right): Planet, Dino, World Map, Ballerina, Worldcup and The band
- Scratch resistant and easy to clean surface with a non-slip back side
- The desk pads convey useful learning content

⇄ 59 cm ⇄ 42 cm ⇄ 0,3 cm

89 Baskets SQ

- A basket set SQ consists of two baskets of the same size, for both sets RD 70 or RD 130
- The set also includes four stacking clips
- The square shape is ideal for Tower 56
- The felt boxes have practical handle eyelets
- Desk utensils can be stored properly
- Available in four colors: blue, grey, green, pink
- The inside of the baskets is grey

Baskets SQ 70 ⇄ 30 cm ⇄ 22 cm ⇄ 8 cm



Baskets SQ 130 ⇄ 19 cm ⇄ 21 cm ⇄ 14 cm

90 Baskets RD

- A basket set RD consists of two baskets of the same size, for both sets RD 70 or RD 130
- The set also includes five stacking clips
- The triangular shape is ideal for Tower 64
- The felt boxes have practical handle eyelets
- Desk utensils can be stored properly
- Available in four colors: blue, grey, green, pink
- The inside of the baskets is grey

Baskets RD 70 ⇄ 22 cm ⇄ 26 cm ⇄ 8 cm



Baskets RD 130 ⇄ 22 cm ⇄ 26 cm ⇄ 14 cm

91 Utensilo beside

- To hang on the desk sides of all moll desks
- Practical organizer
- Made with compartments of different sizes
- In four different colors: Blue, Pink, Green, Grey
- Material: durable polyester
- Loadable up to 2,5 kg.

⇄ 41 cm ⇄ 2 cm ⇄ 24 cm

92 Utensilo behind

- Matches the Flex Deck and Panel
- Practical organizer
- Made with compartments of different sizes
- In four different colors: Blue, Pink, Green, Grey
- Material: durable polyester
- Loadable up to 2,5 kg.

⇄ 48 cm ⇄ 2 cm ⇄ 23 cm

Color sets Trend

Color stripes and color caps



- Six different color stripes and caps: nightshade, lime, khaki, teal and anthracite
- For all moll prime desks and mobile container

- 30 Joker color set Trend
- 34 Winner (Split) color set Trend
- 35 Winner Compact color set Trend
- 46 Champion color set Trend
- 67 Pro/Cubic/Cubicmax color set Trend



MATERIALS, COLORS & PATTERNS ACCESSORIES & ADDITIONS

For the individual design of the moll products we offer a variety of options. For the tables and roll containers, there are two color sets for the color caps and color stripes of the tables. We distinguish between the COLOR SET CLASSIC (blue, green, orange, pink, red, black), which is included with all Prime tables. With the Champion, the colors white & silver are also available.

The COLOR SET TREND (Nightshade, Lime, Khaki, Teal, Magnolia and Anthracite) can be purchased additionally to customize the desks and the roll-containers. There is a special feature: if you buy a Champion with the side panels in Lime, Anthracite or Teal, you get the TREND color set directly with it! Our storage products Baskets and Bottom Silo allow tidiness in the workplace, while the desk

pads inspire and at the same time protect the table tops. We offer the products in lively colors and motifs.

COLOR CAPS & COLOR STRIPES CHAMPION

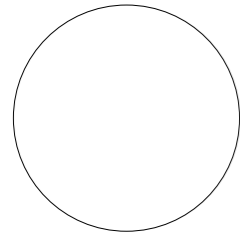

WHITE

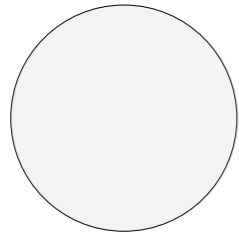

SILVER

COLOR CAPS & COLOR STRIPES COLOR SET CLASSIC

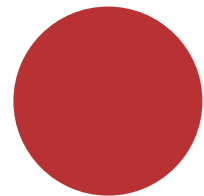

RED

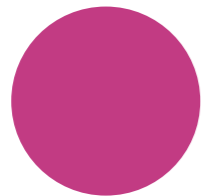

PINK

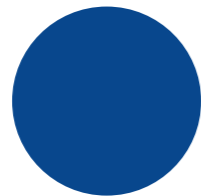

BLUE

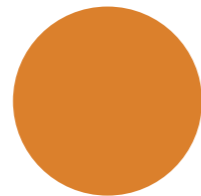

ORANGE



GREEN

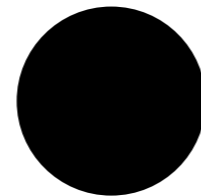

BLACK

COLOR CAPS & COLOR STRIPES COLOR SET TREND

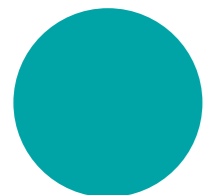

TEAL

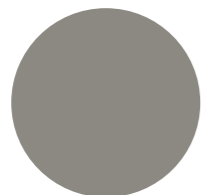

KHAKI

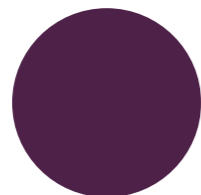

NIGHTSHADE

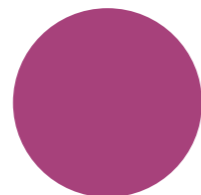

MAGNOLIA



LIME

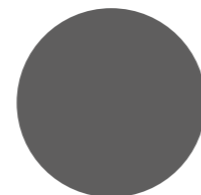

ANTHRACITE

DESK PAD MOTIFS



PLANETS



WORLDMAP



DINO



BALLERINA



WORLD CUP



THE BAND

BASKET COLORS

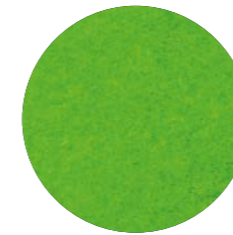

GREEN

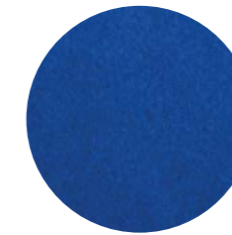

BLUE

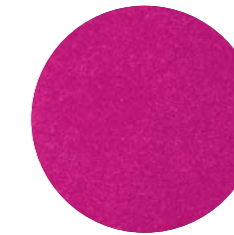

PINK

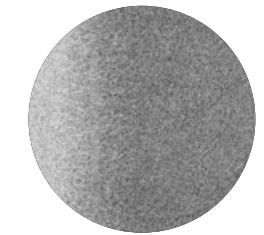

GREY

UTENSILO COLORS



GREEN

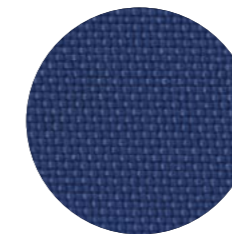

BLUE

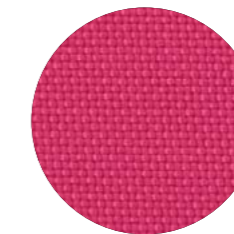

PINK

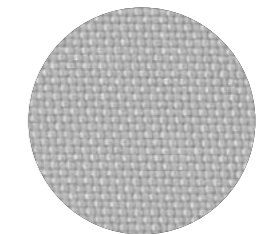

GREY

LIGHT



↔ 45 cm
 ⌀ 41 cm

MOBILIGHT

100 Mobilight

Product features

- The plain white Mobilight made of aluminum with grey plastic applications has a rotatable lamp head with an integrated reflector.
- The swiveling light arm allows for right-handed and left-handed users.
- Energy-saving LED lamps with nominal rated power consumption 6 W; color temperature 3000K (warm white).
- Nominal service life 30,000 h bulbs.
- The patented 15.5 cm wide clamp base is suitable for a table top thickness of 13 to 40 mm and is clamped to the desk top. Holds even when the desk top is at an angle. Bright luminous flux 690 lumens.
- The illuminant is replaceable.

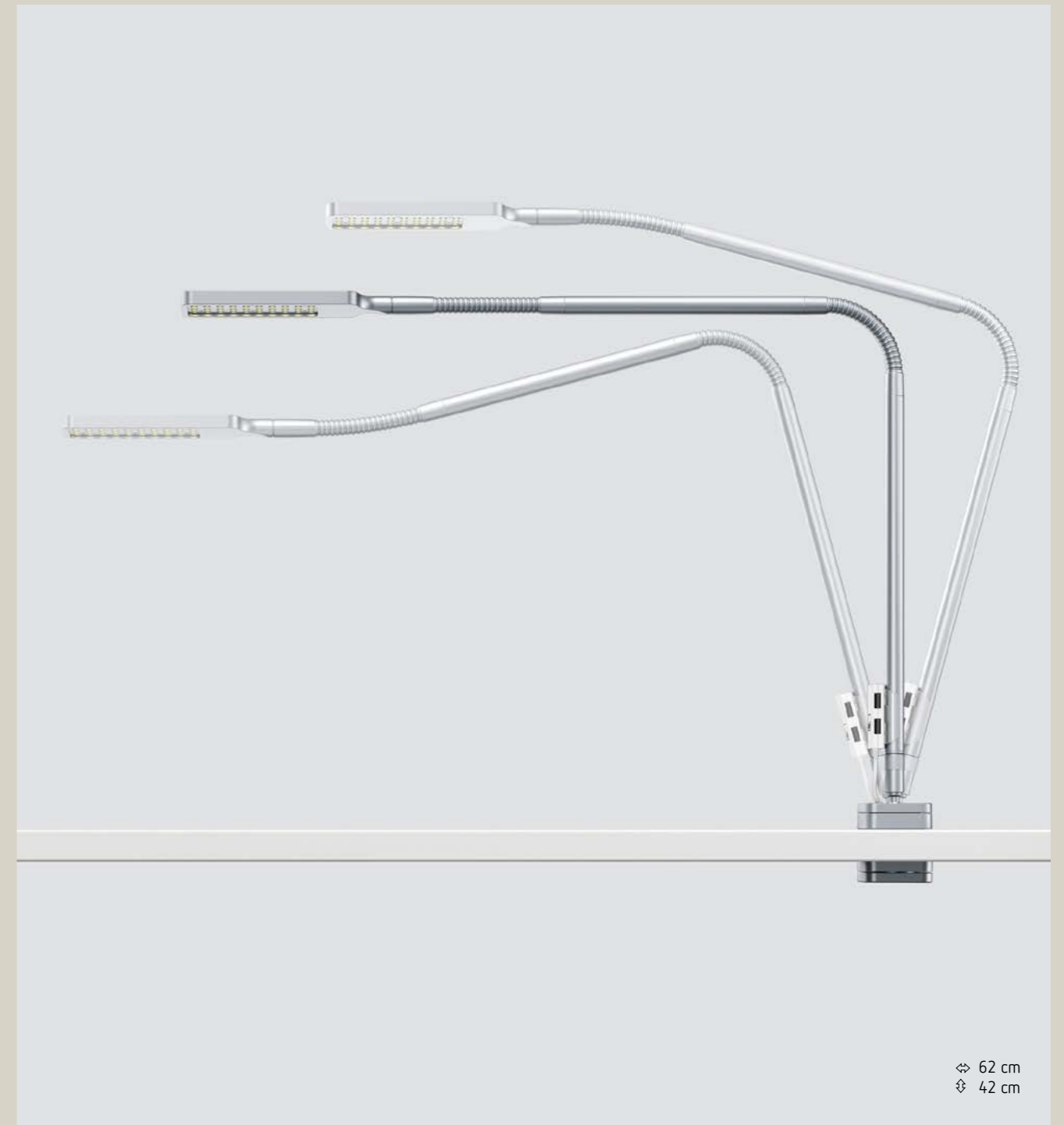

FLEXLIGHT

101 Flexlight

Product features

- The Flexlight has two moveable goosenecks and a ball joint on the clamp base, which allow maximum flexibility when adjusting the desk lamp.
- It also holds when the tabletop is tilted. The clamping foot is designed for a panel thickness of 13 to 25 mm.
- Luminaire head with 40 LEDs of energy efficiency class: G; 85% energy saving compared

to a 90W incandescent bulb; nominal luminous flux 690 lumens; rated power consumption 10 W; color temperature 3500 K; Rated life 25,000 hours. "On" button with additional night light function that can change color with one touch. If required, this function can also be switched off. The lighting is flicker-free via a sensor button and continuously dimmable from 100% to 5%.



“What the world of tomorrow will look like depends to a great extent on the imagination of those who are learning to read right now.”

Astrid Lindgren



CONTACT

IMPRINT

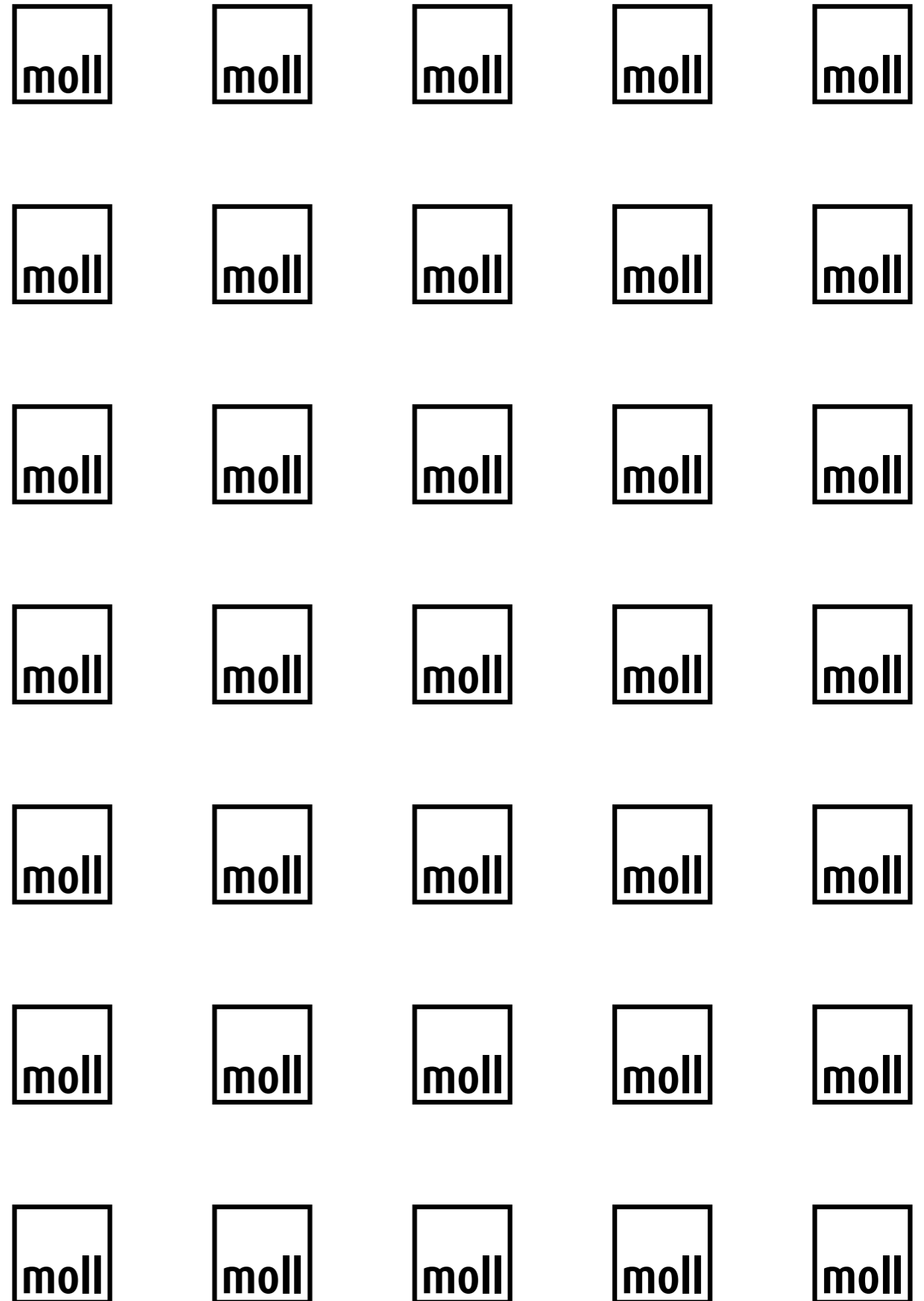

moll Service

T: +49 (0) 7335 181-180 / Email: info@moll.world

We deliver exclusively according to our general terms and conditions.

We reserve the right to make technical changes. We assume no liability for errors in content and printing.

moll Funktionsmöbel GmbH, Rechbergstraße 7, D 73344 Gruibingen,
info@moll.world, www.moll.world ©Copyright by moll 2022

